



FE9714

ABDOMINAL

OWNER'S MANUAL

CAUTION! Read all precautions and instructions in this manual before using this equipment.

Table Of Contents

CAUTION!

Read all precautions and instructions in this manual before using this equipment.

Important Safety Instructions-----	3
Instructions-----	5
Exploded View and Parts List-----	6
Measurement Guide-----	22
Assembly Instructions-----	23
Assembly-----	24
Adjust Instructions-----	37
Exercise Instructions-----	38
Console Panel Function-----	39
Battery Replacement-----	40
Maintenance Schedule-----	41
General Maintenance Information-----	42
Weight Training Tips-----	43

Please assemble according to the actual **Weights** you buy !

Important Safety Instructions

Before beginning any fitness program, you should obtain a complete physical examination from your physician. When using exercise equipment, basic precautions should always be taken, including the following:

1. Read all instructions before using the equipment.
These instructions are written to ensure your safety and to protect the unit.
2. Use the equipment only for its intended purpose as described in this guide.
Do not use accessory attachments that are not recommended by the manufacturer: such attachments might cause injuries.
3. The product should only be used on a level surface and is with 0.5 meters space around the product.
Do not use the equipment outdoors.
4. Do not allow children on or near the equipment. And children are not allowed to use this equipment.
Teenagers should use this equipment with adult supervision.
5. Do not overexert yourself or work to exhaustion.
Do not attempt to lift more weight than you can control safely.
If you feel any pain or abnormal symptoms, stop your workout immediately and consult your physician.
6. This equipment is not used as medical apparatus and instruments.
7. Never operate the unit when it has been dropped or damaged.
Never drop or insert anything into any opening in the equipment.
Always check the unit and its cables before each use. Make sure that all fasteners and cables are secure and in good working condition.
Frayed or worn cables can be dangerous and may cause injury. Periodically check these cables for any indication of wear.
Keep hands, limbs, loose clothing and long hair well out of the way of moving parts.
8. Be careful when getting on or off the equipment.
9. Wear proper exercise clothing and shoes for your workout, no loose clothing.

Important Safety Instructions

Personal Safety During Assembly

Read each step in the assembly instructions and follow the steps in sequence. Do not skip ahead. If you skip ahead, you may learn later that you have to disassemble components and that you may have damaged the equipment.

Assemble and operate the equipment on a solid, level surface. Locate the unit a few feet from walls or furniture to provide easy access. The equipment is designed for your enjoyment. By following these precautions and using common sense, you will have many safe and pleasurable hours of healthful exercise with the equipment.

Training Area and Free Area

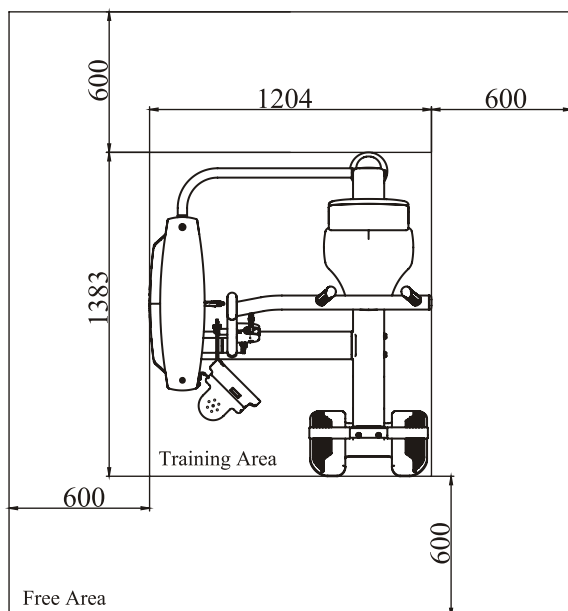

Specifications

Class: S

Maximum Wt. Capacity: 134kg/ 295lbs

Maximum User Weight: 150kg/ 330lbs

Product Total Surface: 1204*1383mm

Product Total Mass: 141.5 kg/ 312 lbs

Instructions

Before beginning assembly please take the time to read instructions thoroughly. Please use the various lists in this manual to make sure that all parts have been included in your shipment. When ordering, use part number and description from the lists. Use only our replacement part when servicing. Failure to do so will void your warranty and could result in personal injury.

The equipment is designed to provide the smoothest, most effective exercise motion possible. After assembly, you should check all functions to ensure correct operation. If you experience problems, first recheck the assembly instructions to locate any possible errors made during assembly. If you are unable to correct the problem, call your authorized dealer. Be sure to have your serial number and this manual when calling. When all parts have been accounted for, continue on.

Tools Required



Ratchet Wrench and Socket



Adjustable Wrench



Rubber Mallet

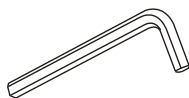

Hex Key Wrench Set



Phillips Screwdriver

Exploded View and Parts List

Weight Stack Frame Assy

ItemNo.	Grade No.	Part No.	Description	QTY
1	1.1	FE97140100	Weight Stack Frame	1
2	1.2	FE97211200	Top clamping plate	1
3	1.3	FE97011500	Foot Plate	2
4	1.4	FE97122000	Plate for Sensor	1
5	1.5	IE951814700	Magnetic Iron	2
6	1.6	FE97123000	Cover for Magnetic Iron	1
7	1.7	GB846ST2.9*9.5DS	Screw ST2.9*9.5	4
8	1.8	DQDCH02	Cell Box	1
9	1.9	SMJ20*1*1000	Double faced adhesive tape	0.1
10	1.10	DQCGQ01	Sensor	2
11	1.11	GB17880.5M6*16.5DS17	Rivet Nut M6	4
12	1.12	GB9510DN2	Flat Washer $\Phi 11 * \Phi 20 * 2$	4
13	1.13	GB956DN2	Flat Washer $\Phi 6.6 * \Phi 12 * 1.6$	4
14	1.14	NM10DN2	Nylon Lock Nut M10	2
15	1.15	FE97123900	Belt Pulley $\Phi 76$	2
16	1.16	GB936N19	Spring Washer $\Phi 6$	4
17	1.17	PNLM6*12DN20	Button Head Cap Screw M6*12	4
18	1.18	GB70BTM10*75DN18	Socket Head Cap Screw M10*75	2
19	1.19	PNLM8*25DN20NL	Button Head Cap Screw M8*25	2
20	1.20	GB17880.5M8*16.5DCS17	Rivet Nut M8	4
21	1.21	GB818M3*8DS2	Screw M3*8	4
22	1.22	AC32705800	U-nut M6	6

Exploded View and Parts List

Weight Stack Frame Assy

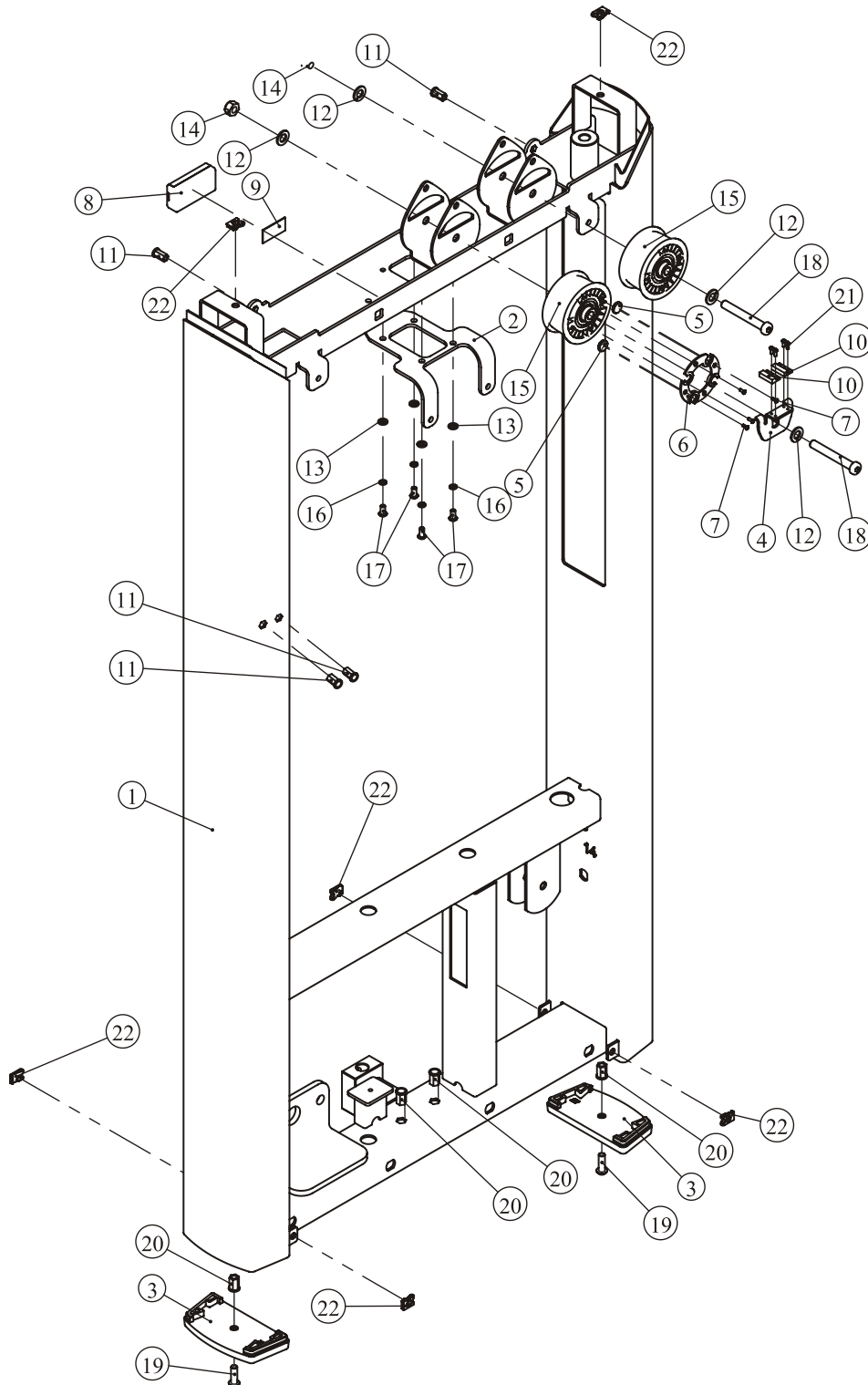

Exploded View and Parts List

Belt ASSY

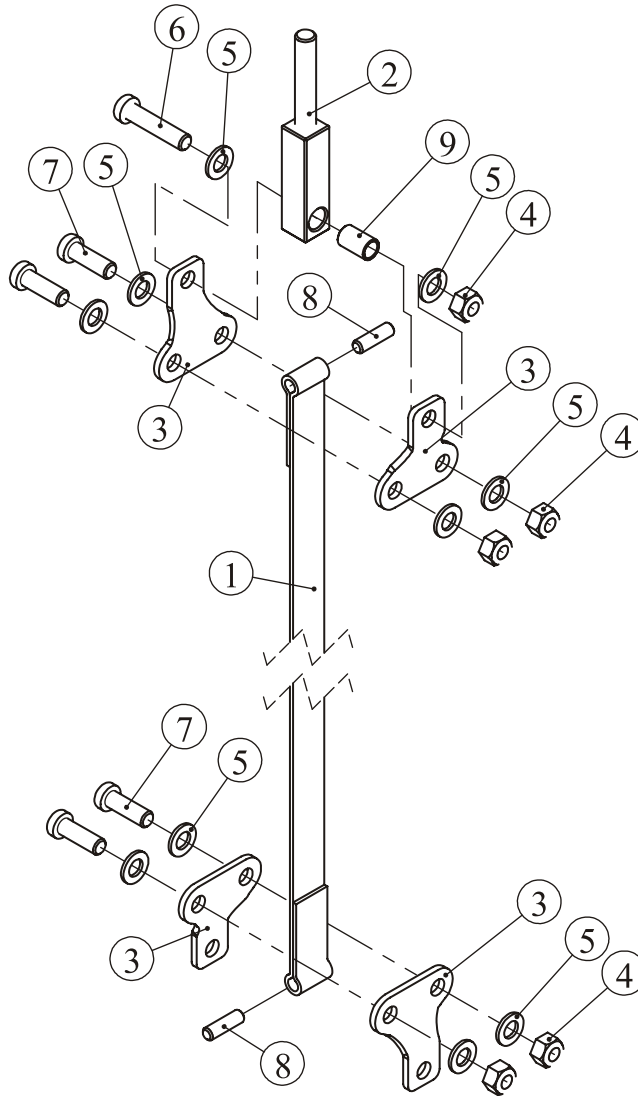

ItemNo.	Grade No.	Part No.	Description	QTY
1	54.1	FE97214500	Belt	1
2	54.2	FE97214700	Square Adjustment Lever	1
3	54.3	FE97193300	Fastening Plate	4
4	54.4	NM10DN2	Nylon Lock Nut M10	5
5	54.5	GB9510DN2	Flat Washer $\Phi 11 * \Phi 20 * 2$	10
6	54.6	GB70BTM10*45DN18	Socket Head Cap Screw M10*45	1
7	54.7	GB70BTM10*30DN18	Socket Head Cap Screw M10*30	4
8	54.8	2.00105E+11	Locating Pin $\Phi 8 * 28$	2
9	54.9	FE972111500	Spacer $\Phi 13 * \Phi 10.3 * 21$	1

Exploded View and Parts List

Main Frame ASSY

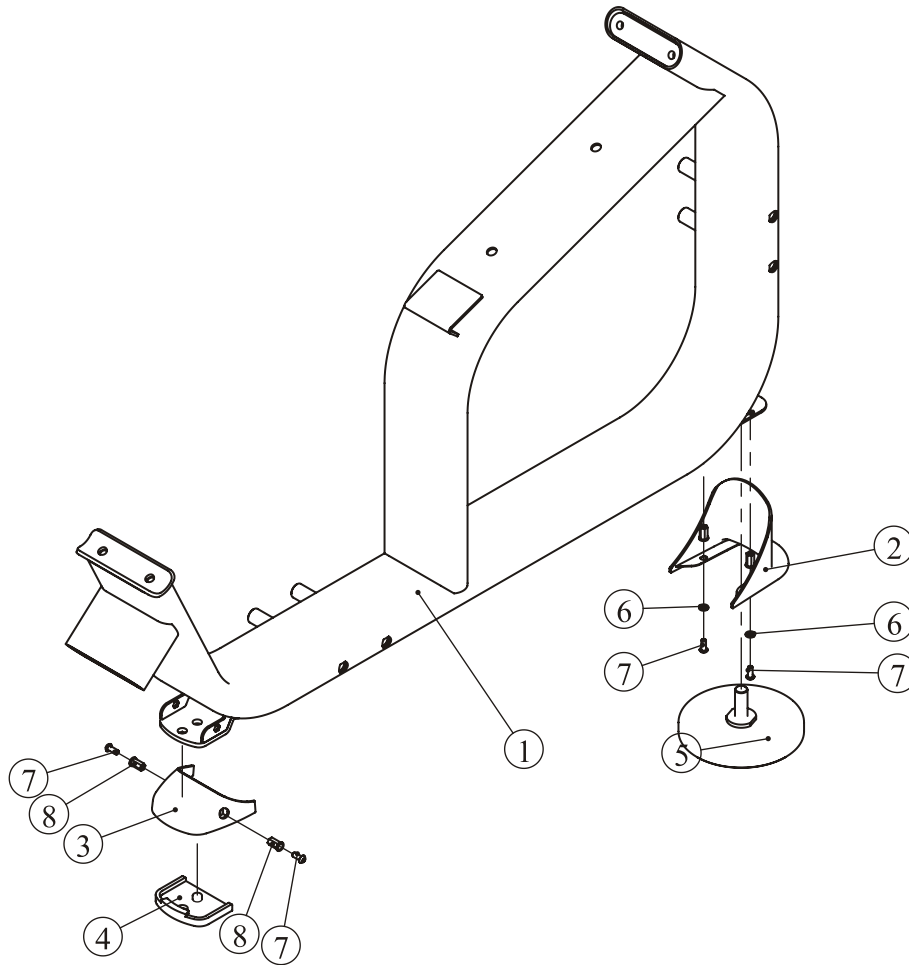

ItemNo.	Grade No.	Part No.	Description	QTY
1	2.1	FE97140200	Main Frame	1
2	2.2	FE97211700	Rear ground plastic cover	1
3	2.3	FE97211600	Front ground plastic cover	1
4	2.4	FE97211800	Rubber Foot	1
5	2.5	IT93201800	Adjustable Foot plate	1
6	2.6	GB956DN2	Flat Washer $\Phi 6.6 * \Phi 12 * 1.6$	2
7	2.7	PNLM6*15DN20	Button Head Cap Screw M6*15	4
8	2.8	GB17880.5M6*16.5DS17	Rivet Nut M6	4

Exploded View and Parts List

Flange ASSY

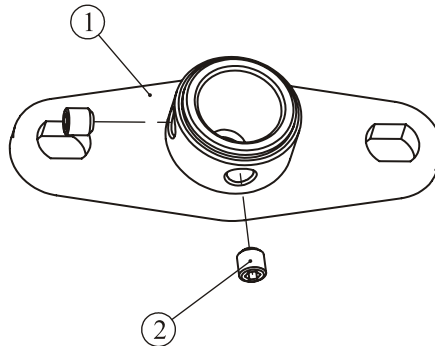

ItemNo.	Grade No.	Part No.	Description	QTY
1	12.1	FE97210800	Flange	1
2	12.2	GB77M8*8DS18	Screw M8*8	2

Cam Frame ASSY

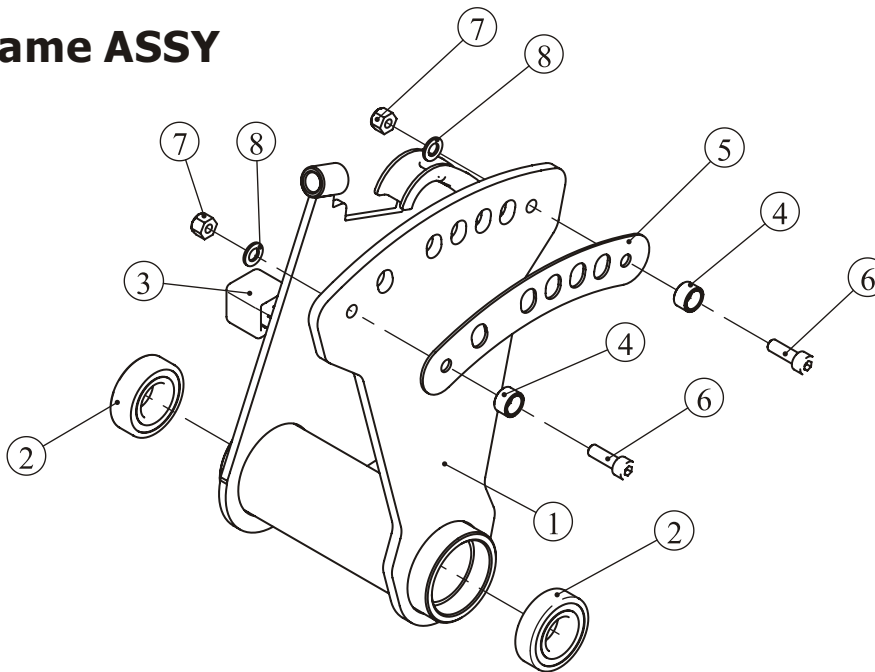

ItemNo.	Grade No.	Part No.	Description	QTY
1	4.1	FE97140400	Cam Frame	1
2	4.2	GB2766205-2ZNBK	Bearing 6205-2Z	2
3	4.3	FE97213100	Square Rubber Sleeve	1
4	4.4	IN-S10111200	Rubber Sleeve $\Phi 17*10.5$	2
5	4.5	FE97141900	Fanshaped Adjustment Plate	1
6	4.6	GB70M8*25DN20	Socket Head Cap Screw M8*25	2
7	4.7	NM8DN2	Nylon Lock Nut M8	2
8	4.8	GB958DN2	Flat Washer $\Phi 9*\Phi 16*1.6$	2

Exploded View and Parts List

Turn Arm Frame Assy

ItemNo.	Grade No.	Part No.	Description	QTY
1	6.1	FE97140600	Turn Arm Frame	1
2	6.2	FE971410ASSY	Adjustment Handle Frame ASSY	1
3	6.3	FE970114600	Aluminium Grip Cap	2
4	6.4	FE970114500	Aluminium Grip Ring	2
5	6.5	FE972114700	Grip	2
6	6.6	FE97145300	Turning Point Cover I	1
7	6.7	FE97145400	Turning Point Cover II	1
8	6.8	FE97142500	Plug RT40*118*3	1
9	6.9	KPS18002701V1	Lock Nut M20*1.5*18	1
10	6.10	CWRVL0272600	Connecting Plate	2
11	6.11	GB2766205-2ZNBK	Bearing 6205-2Z	2
12	6.12	FE97211900	Cap Φ 60	1
13	6.13	DQ5DN2	Flat Washer Φ 5.5* Φ 12*1	4
14	6.14	GB70M5*25DN20	Socket Head Cap Screw M5*25	2
15	6.15	NM5DN2	Nylon Lock Nut M5	2
16	6.16	GB70BTM10*20DN18	Socket Head Cap Screw M10*20	1
17	6.17	GB70M8*60DN20	Socket Head Cap Screw 8*60	1
18	6.18	NM8DN2	Nylon Lock Nut M8	1
19	6.19	FE971411700	Pin axle	1
20	6.20	SG8007M1200B	Spring	1
21	6.21	GB77M5*10N19	Screw M5*10	4
22	6.22	GB77M5*6N19	Screw M5*6	4

Exploded View and Parts List

Turn Arm Frame Assy

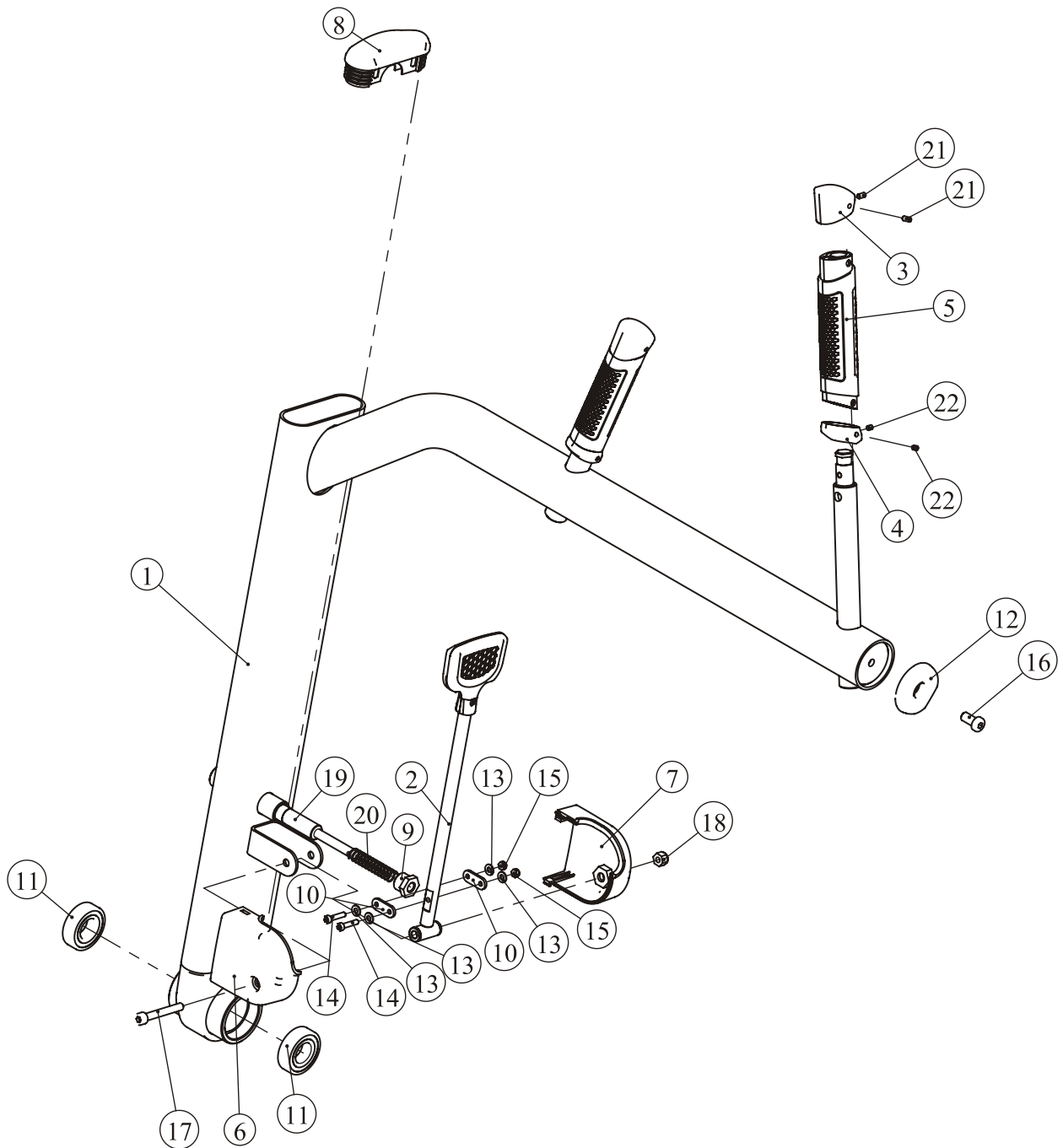

Exploded View and Parts List

Adjustment Handle Frame ASSY

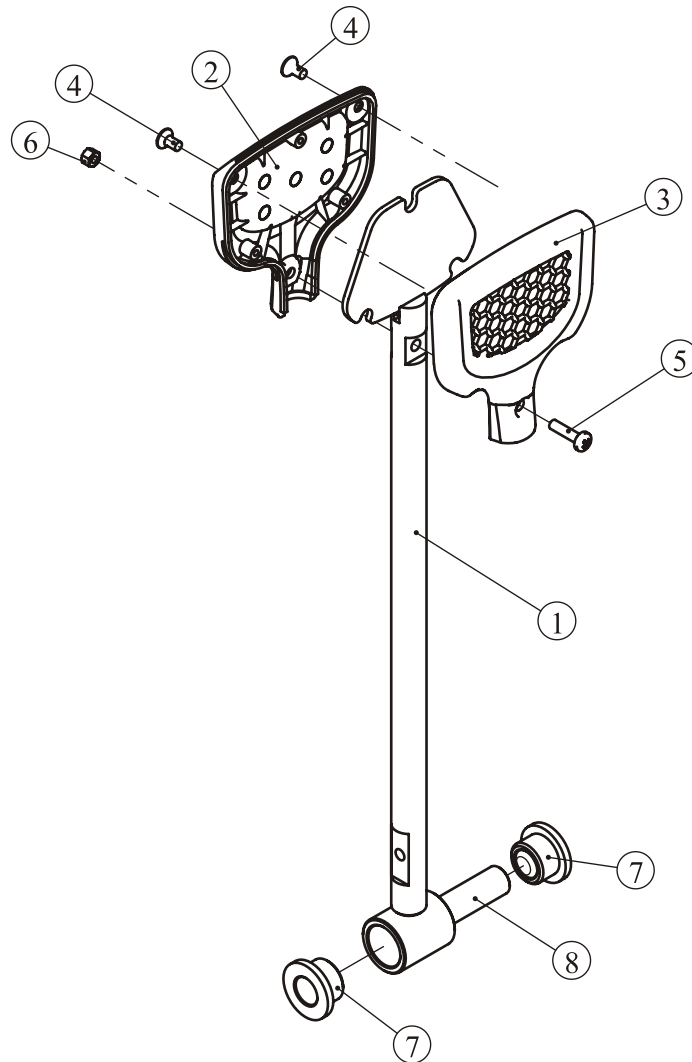

ItemNo.	Grade No.	Part No.	Description	QTY
1	6.2.1	FE97141000	Adjustment Handle Frame	1
2	6.2.2	FE970114200	Upper Regulation cover	1
3	6.2.3	FE970114100	Lower Regulation cover	1
4	6.2.4	GB819M4*8DN2	Screw M4*8	2
5	6.2.5	GB818M4*16DN2	Screw M4*16	1
6	6.2.6	GB41M4DN2	Hexagon Nut M4	1
7	6.2.7	GB818M4*16DN2NL	Screw M4*16	1
8	6.2.8	FE97141800	Spacer Bush $\Phi 12^* \Phi 8^*35.5$	1

Exploded View and Parts List

Foot Frame ASSY

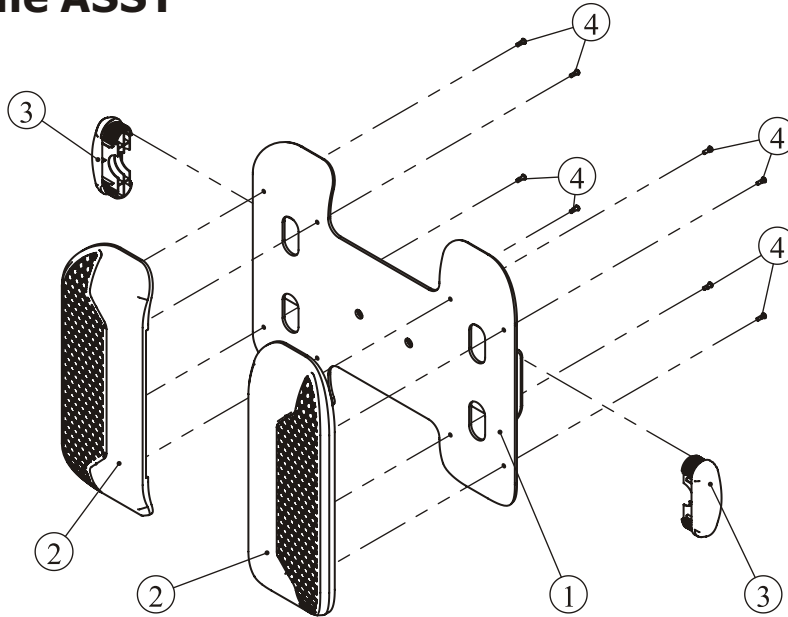

ItemNo.	Grade No.	Part No.	Description	QTY
1	7.1	FE97140900	Foot Frame	1
2	7.2	FE97192400	Foot Cover Plate	2
3	7.3	FE97142500	Plug RT40*118*3	2
4	7.4	PNLM4*10DN20	Button Head Cap Screw M4*10	8

Circular Foot Frame ASSY

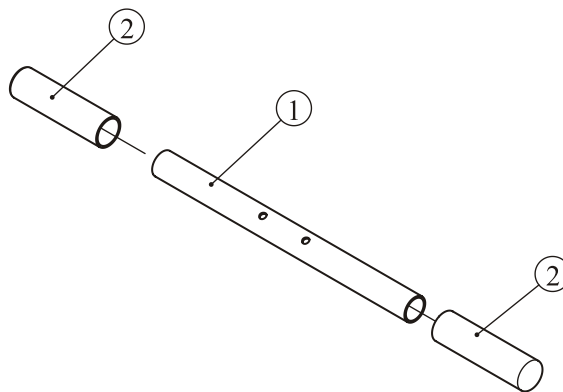

ItemNo.	Grade No.	Part No.	Description	QTY
1	8.1	FE97141600	Foot Set Tube	1
2	8.2	FE970112000	Foot Set	2

Exploded View and Parts List

Top plate ASSY

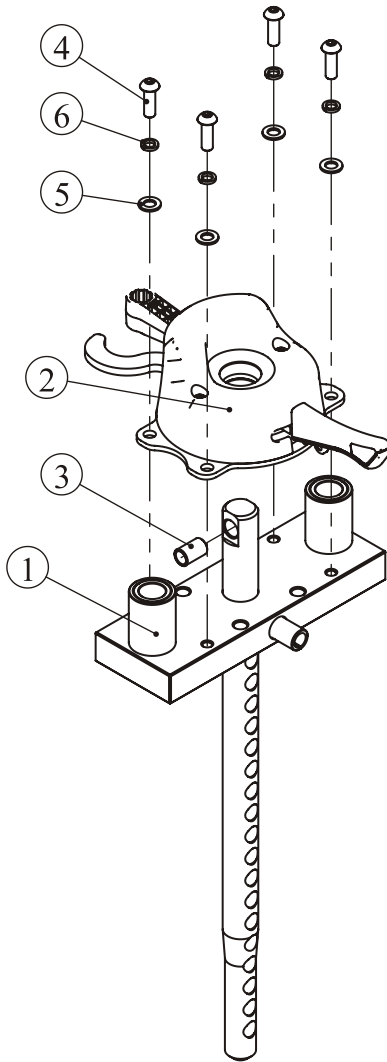

ItemNo.	Grade No.	Part No.	Description	QTY
1	70.1	FE97193000	Top plate	1
2	70.2	FE971938ASSY	Counter weight ASSY	1
3	70.3	FE972111500	Spacer $\Phi 13^* \Phi 10.3^* 21$	1
4	70.4	PNLM8*25DN20	Button Head Cap Screw M8*25	4
5	70.5	GB958DN2	Flat Washer $\Phi 9^* \Phi 16^* 1.6$	4
6	70.6	GB938N19	Spring Washer $\Phi 8$	4

Exploded View and Parts List

Counter weight ASSY

ItemNo.	Grade No.	Part No.	Description	QTY
1	70.2.1	FE97192700	Plastic base	1
2	70.2.2	FE97192800	Counter weight Plastic cover	1
3	70.2.3	FE97193500	Base plate	1
4	70.2.4	FE97193600	Shifting fork	1
5	70.2.5	FE97193700	Top plate	1
6	70.2.6	FE97193800	Guide Frame	1
7	70.2.7	FE97193900	Short Spacer $\Phi 45^* \Phi 26^*7.5$	1
8	70.2.8	FE97194000	Stop collar	1
9	70.2.9	FE97194100	Top plastic cover	1
10	70.2.10	FE97194200	Base plastic cover	1
11	70.2.11	CWRVL0251800	Steel ball support base	2
12	70.2.12	CWRVL0251900	Spring $\Phi 1.2^* \Phi 13^*11$	3
13	70.2.13	GB3088G20	Steel ball	2
14	70.2.14	PNLM8*80DN20	Button Head Cap Screw M8*80	2
15	70.2.15	PNLM8*45DN20	Button Head Cap Screw M8*45	2
16	70.2.16	PNLM4*12DN20	Button Head Cap Screw M4*12	2
17	70.2.17	PNLM5*15DN20	Button Head Cap Screw M5*15	2
18	70.2.18	GB958DN2	Flat Washer $\Phi 9^* \Phi 16^*1.6$	4
19	70.2.19	GB938N19	Spring Washer $\Phi 8$	4

Exploded View and Parts List

Counter weight ASSY

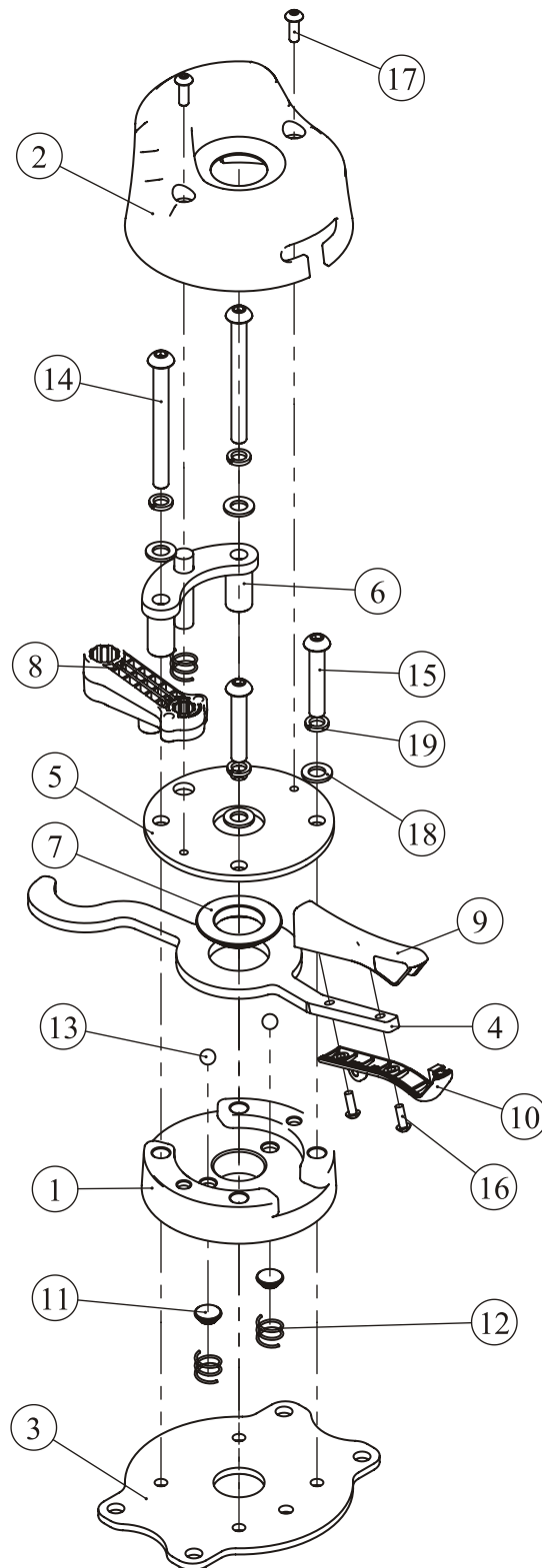

Exploded View and Parts List

Training Placard Cover ASSY

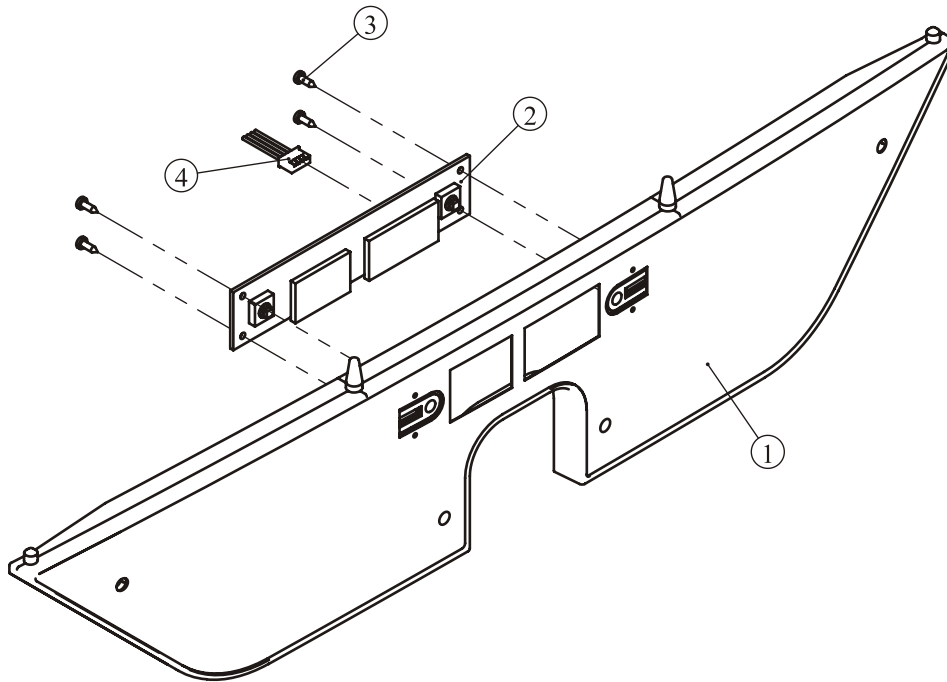

ItemNo.	Grade No.	Part No.	Description	QTY
1	62.1	FE97052600	Training placard cover	1
2	62.2	B117	Console PCB	1
3	62.3	GB845ST2.9*9.5DS	Screw ST2.9*9.5	4
4	62.4	L350XHP/SMY-4	Sensor 4C*22#350mm	1

5LBS Counter Weight ASSY

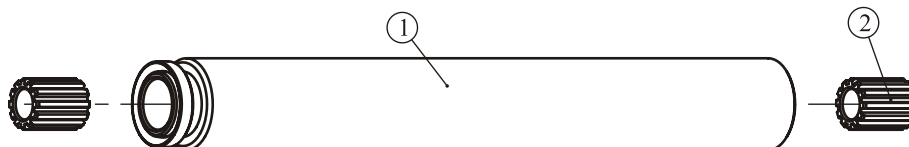

ItemNo.	Grade No.	Part No.	Description	QTY
1	67.1	FE97213500	5LBS Counter Weight	1
2	67.2	CXT-1001900V1	Guide Sleeve	2

Exploded View and Parts List

Overall

ItemNo.	Grade No.	Part No.	Description	QTY
1	1	FE971401ASSY	Weight Stack Frame Assy	1
2	2	FE971402ASSY	Main Frame Assy	1
3	3	FE97140300	Side Connecting Frame	1
4	4	FE971404ASSY	CAM ASSY	1
5	5	FE97140500	Connect Frame	1
6	6	FE971406ASSY	Turn Arm Frame Assy	1
7	7	FE971409ASSY	Foot Frame ASSY	1
8	8	FE971416ASSY	Circular Foot Frame ASSY	1
9	9	FE97192600	Plastic Cover II	1
10	10	FE97142000	Shaft $\Phi 25*302$	1
11	11	IT80023000	Plug Bumper $\Phi 63.5*\Phi 19*25.4$	2
12	12	FE972108ASSY	Flange ASSY	1
13	13	FE97210900	Bracket of Belt Pulley	1
14	14	C170C1700	Flange Gasket $\Phi 35*\Phi 25.4*2$	1
15	15	FE97211400	Underside support plate	1
16	16	FE97053500	Cup Holder	1
17	17	FE97053600	Bracket of Cup Holder	1
18	18	FE97082200	Seat Pad	1
19	19	FE97192500	Plastic Cover I	2
20	20	FE97143000	Waist Pad	1
21	21	FE97213400	Rubber Sleeve $\Phi 30*65$	2
22	22	FE97194300	Guide Rod $\Phi 14$	1
23	23	FE97144400	Limiting Tube $\Phi 22*2*387$	1
24	24	CWRVL0251000	Plug Bumper $\Phi 14*\Phi 40*25.4$	1
25	25	FE97214000	Narrow Belt Pulley $\Phi 76$	1
26	26	FE97143300	Waist Pad Plate	1
27	27	CWRVL0250900	Flat Washer $\Phi 15*\Phi 40*3$	1
28	28	FE97214800	Belt Rubber Sleeve $\Phi 17*49$	2
29	29	GB956DN2	Flat Washer $\Phi 6.6*\Phi 12*1.6$	17
30	30	GB9512DN2	Flat Washer $\Phi 13*\Phi 24*2.5$	17
31	31	GB958DN2	Flat Washer $\Phi 9*\Phi 16*1.6$	4
32	32	GB9510DN2	Flat Washer $\Phi 11*\Phi 20*2$	13
33	33	GB77M8*8DS18	Screw M8*8	1
34	34	GB70BTM12*105DN18	Socket Head Cap Screw M12*105	2
35	35	GB70BTM12*65DN18NL	Socket Head Cap Screw M12*65	2
36	36	GB70BTM12*180DN18NL	Socket Head Cap Screw M12*180	4
37	37	GB70BTM12*120DN18NL	Socket Head Cap Screw M12*120	2
38	38	GB70BTM10*65DN18	Socket Head Cap Screw M10*65	5
39	39	GB70BTM10*45DN18	Socket Head Cap Screw M10*45	2

Exploded View and Parts List

Overall

ItemNo.	Grade No.	Part No.	Description	QTY
40	40	GB70BTM10*25DN18NL	Socket Head Cap Screw M10*25	5
41	41	GB70BTM10*55DN18NL	Socket Head Cap Screw M10*55	1
42	42	GB70M8*25DN20	Socket Head Cap Screw M8*30	2
43	43	PNLM6*15DN20	Button Head Cap Screw M6*15	6
44	44	CNLM12*30DS20	Flat Head Cap Screw M12*30	2
45	45	PNLM6*20DN20	Button Head Cap Screw M6*20	11
46	46	GB70M12*35DS20NL	Socket Head Cap Screw M12*35	2
47	47	PNLM8*25DN20	Button Head Cap Screw M8*25	2
48	48	GB9310N19	Spring Washer Φ 10	1
49	49	GB938N19	Spring Washer Φ 8	2
50	50	GB936N12	Spring Washer Φ 6	2
51	51	GB8966FH12	Shaft Ring Opening Φ 6	2
52	52	NM12DN2	Nylon Lock Nut M12	5
53	53	NM10DN2	Nylon Lock Nut M10	4
54	54	FE972145ASSY	Belt ASSY	1
55	55	FE97142600	Guide Rod Φ 19*974	2
56	56	FE97144600	Cable	1
57	57	FE97142800	Front Lower Cover	1
58	58	FE97052500	Front Shroud	2
59	59	FE97011600	Top Cover	1
60	60	FE97052900	Back Lower Cover	1
61	61	FE97052800	Back Shroud	1
62	62	FE970526ASSY	Training Placard Cover ASSY	1
63	63	AC31001301V1	Motor End Washer	1
64	65	SG500110400V2	4.5" Pulleys	1
65	66	CWRVL0014000	Pulleys Baffle	1
66	67	FE972135ASSY	5LBS Counter Weight ASSY	1
67	69	FE97143200	Waist Pad Cover	1
68	70	FE971930ASSY	Waist Pad Cover	1
69	71	FE97123800	Selector Pin W/Coil	1
70	72	FE97053700	Plastic End Cap	1
71	73	FE97216900	Spacer Pin Φ 13* Φ 8*65.5	2
72	100	YHY	Lube	1
73	101	NBS6DHS	Hex Key S=6	1
74	102	NBS5DHS	Hex Key S=5	1
75	103	LW200BS	Wrench Φ 6*117	1
76	104	NBS8DHS	Hex Key S=8	1
77	105	NBS10DHS	Hex Key S=10	1
78	107	PNLM6*12DN20	Button Head Cap Screw M6*12	2
79	108	NBS4DHS	Hex Key S=4	1

Exploded View and Parts List

Overall

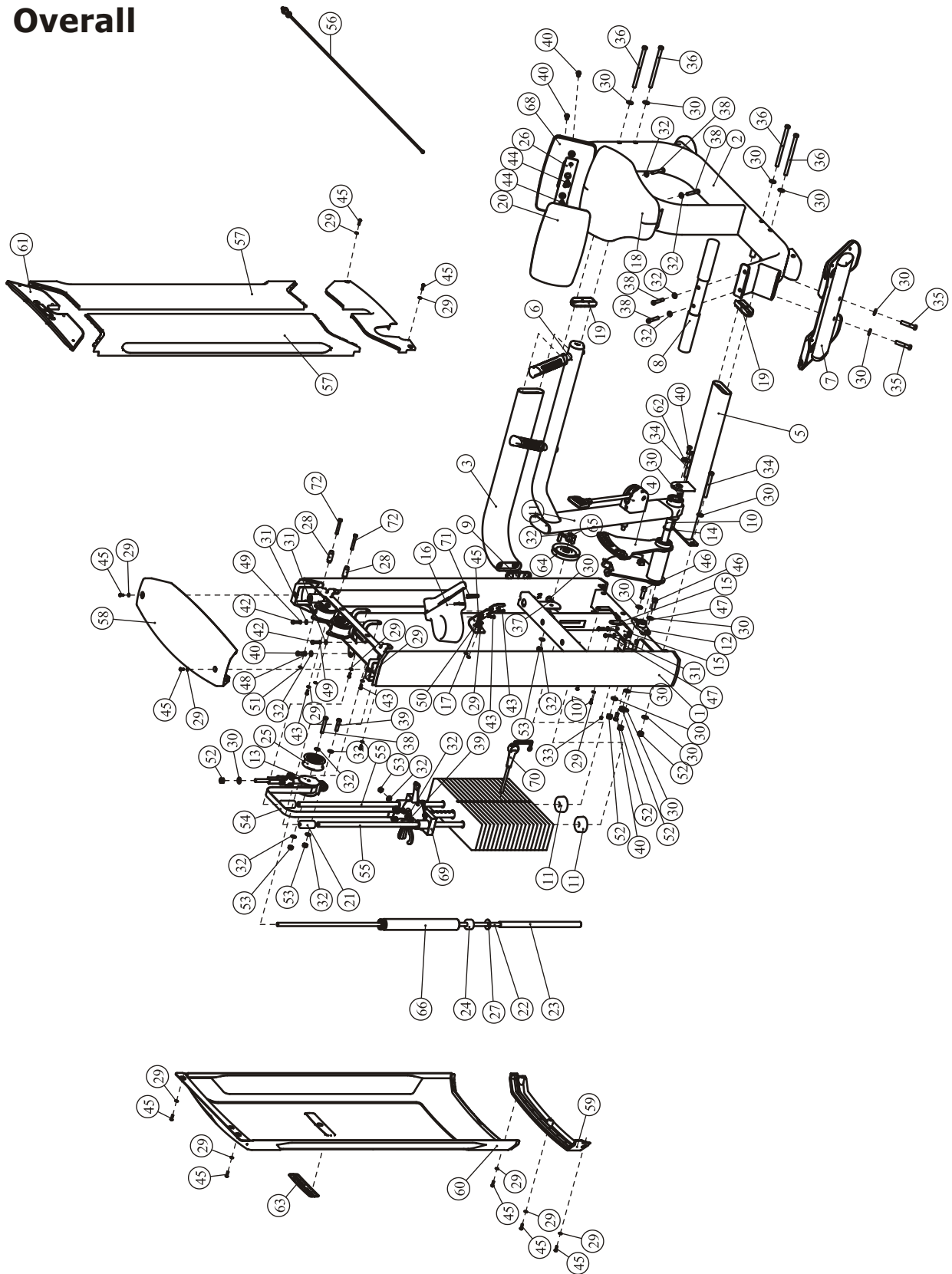

Measurement Guide

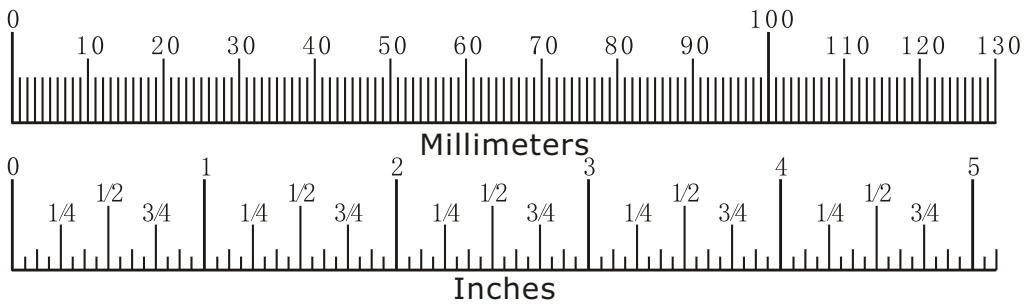
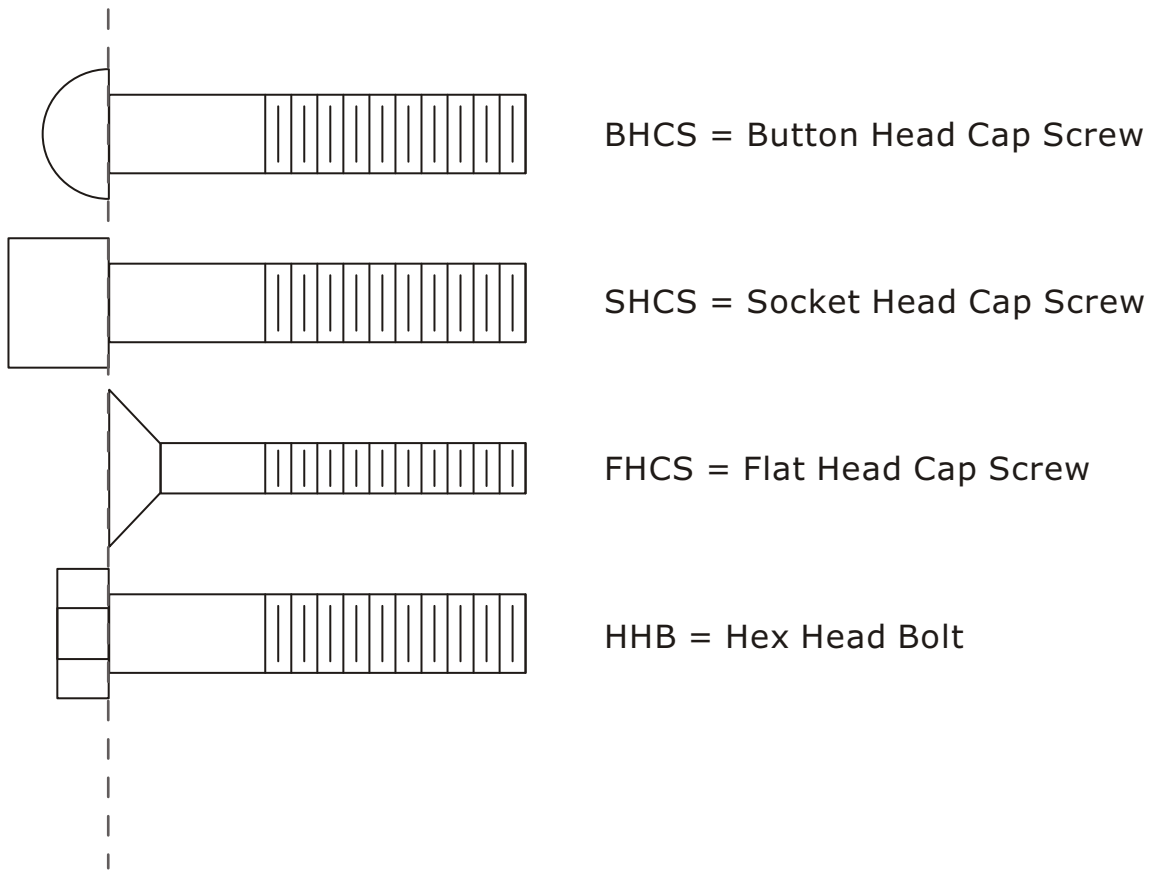

Diameter of bolt (mm/inch)	M6(1/4")	M8(5/16")	M10(3/8")	M12(1/2")	M16(5/8")
Tightening torque (N.m)	9~12	22~30	45~59	78~104	193~257
Operational methods for adult men	The strength of the wrist	The strength of the wrist and forearm	The strength of the entire arm	The strength of the arm and upper body	with all strength

Assembly Instructions

Assembly of the equipment takes professional installers about 2 hours. If this is the first time you have assembled this type of equipment, plan to spend more time. It is strongly recommended to assemble the equipment by professional installers. You may find it quicker, safer, easier to assemble this equipment with the help of a friend, as some of components may be large, heavy or awkward to handle alone. It is important that you assemble your product in a clean, clear, uncluttered area. This will enable you to move around the product while you are fitting components and reduce the possibility of injury during assembly.

NOTE

As with any assembled part, proper alignment and adjustment is critical. While tightening the fasteners, be sure to leave room for adjustments. Do not fully tighten the fasteners until instructed to do so. Be careful to assemble the components in the sequence presented in this guide.

Assembly

STEP 1

1. Attach The Flange ASSY (#12) to The Weight Stack Frame Assy (#1) using:
two M12*35 Socket Head Cap Screw (#46) four Flat Washer $\Phi 13*\Phi 24*2.5$ (#30)
two M12 Nylon Lock Nut (#52)
2. Attach The 4.5" Pulleys (#65) and the Pulleys Baffle (#66) to The Weight Stack Frame Assy (#1) using:
one M10*55 Socket Head Cap Screw (#41) two Flat Washer $\Phi 11*\Phi 20*2$ (#32)
one M10 Nylon Lock Nut (#53)
3. Attach The CAM ASSY (#4) and The Connect Frame (#5) and The Turn Arm Frame Assy (#6) to The Weight Stack Frame Assy (#1) using:
one Shaft $\Phi 25*302$ (#10) one Flange Gasket $\Phi 35*\Phi 25.4*2$ (#14)
one Motor End Washer (#63) two M10*25 Socket Head Cap Screw (#40)
two M12*105 Socket Head Cap Screw (#34) two M12 Nylon Lock Nut (#52)
four Flat Washer $\Phi 13*\Phi 24*2.5$ (#30)

Note: Hand tighten Bolts and Nylon Lock Nuts until machine is fully assembled.

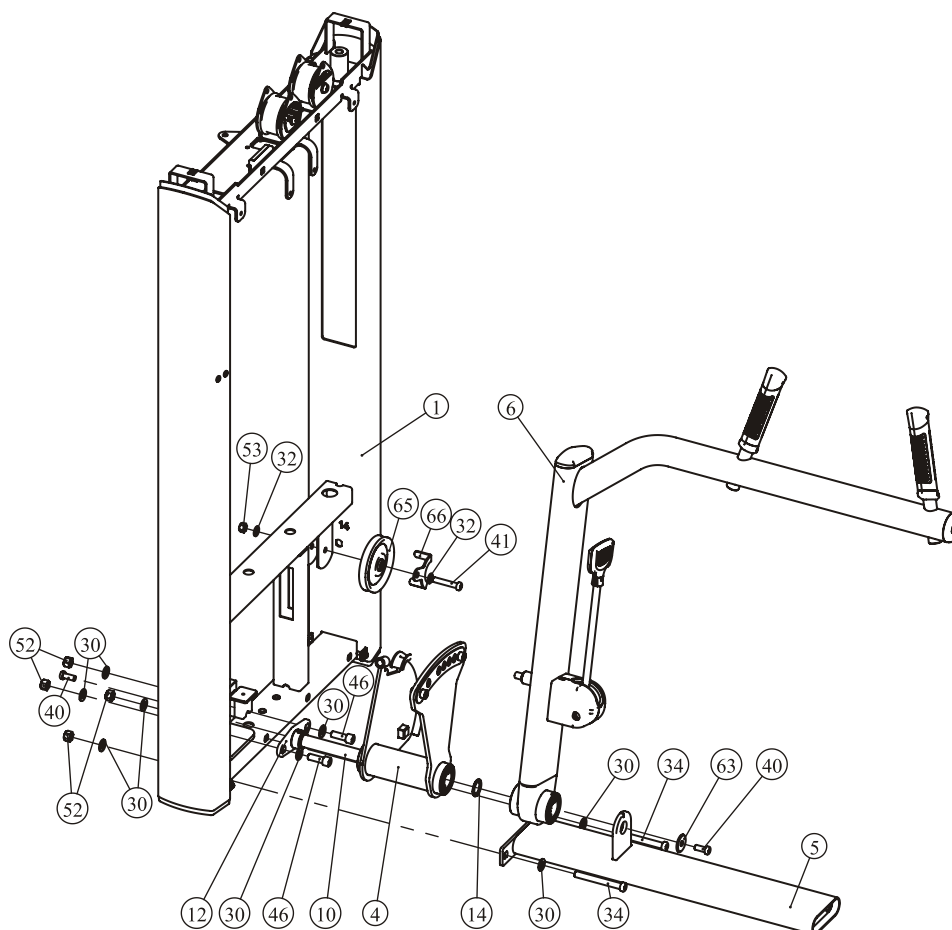

Assembly

STEP 3

1. Attach The Underside Support Plate (#15) to the Weight Stack Frame Assy (#1) using:
 - two M8*25 Button Head Cap Screw (#47)
 - two Flat Washer $\Phi 9*\Phi 16*1.6$ (#31)
2. Attach The Front Lower Cover (#57) to the Weight Stack Frame Assy (#1) using:
 - four Flat Washer $\Phi 6.6*\Phi 12*1.6$ (#29)
 - two M6*12 Button Head Cap Screw (#107)
 - two M6*20 Button Head Cap Screw (#45)

Note: Wrench Tighten Bolts and Nylon Lock Nuts.

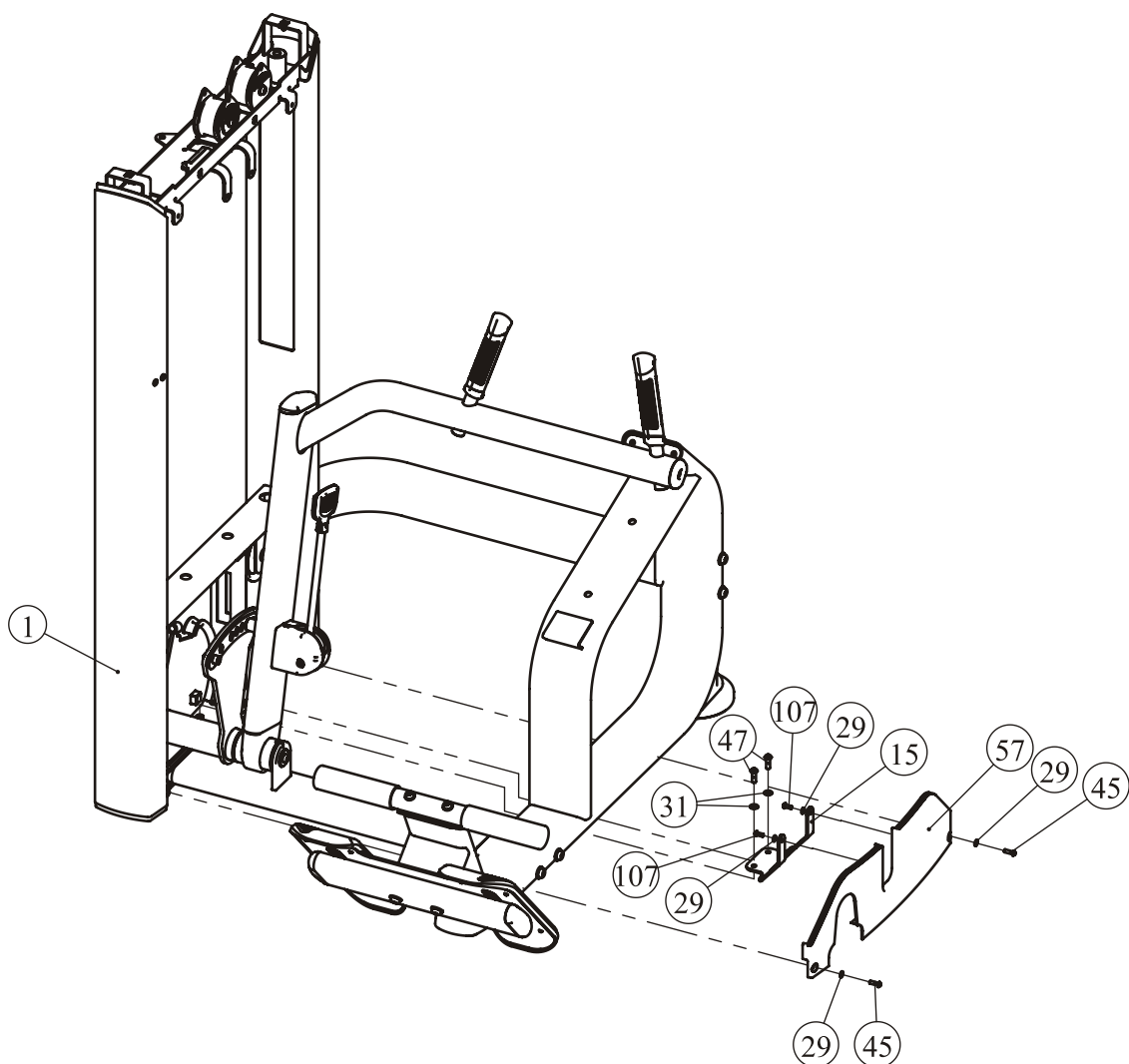

Assembly

STEP 4 Here is the assembly instruction for 15LBSx15PCS Weights !

1. Attach:

two $\Phi 19 \times 974$ Guide Rods (#55)
 fifteen Weight Plate 15LBS (#150)
 two weight stack space (#151)
 to The Weight Stack Frame Assy (#1) using:
 two M8*30 SHCS (#42)
 two $\Phi 30 \times 65$ Rubber Sleeve (#21)

two $\Phi 63.5 \times \Phi 19 \times 25.4$ Plug Bumper (#11)
 one Top plate ASSY (#70)

two $\Phi 9 \times \Phi 16 \times 1.6$ Flat Washers (#31)
 two $\Phi 8$ Spring Washer (#49)

2. Attach The Selector Pin W/Coil (#71) to The Top plate ASSY (#70).

3. Loosen one M8*8 Screw (#33), and Attach:

one $\Phi 14 \times 1296$ Guide Rod (#22)
 to The Weight Stack Frame Assy (#1) using:
 one $\Phi 22 \times 2 \times 387$ Limiting tube (#23)
 one $\Phi 14 \times \Phi 40 \times 25.4$ Plug Bumper (#24)
 one $\Phi 10$ Spring Washer (#48)

one 5LBS Counter Weight ASSY (#67)
 one $\Phi 15 \times \Phi 40 \times 3$ Flat Washer (#27)
 one M10*25 SHCS (#40)
 one $\Phi 11 \times \Phi 20 \times 2$ Flat Washer (#32)

4. Wrench Tighten M8*8 Screw (#33).

Note: Wrench Tighten Bolts and Nylon Lock Nuts.

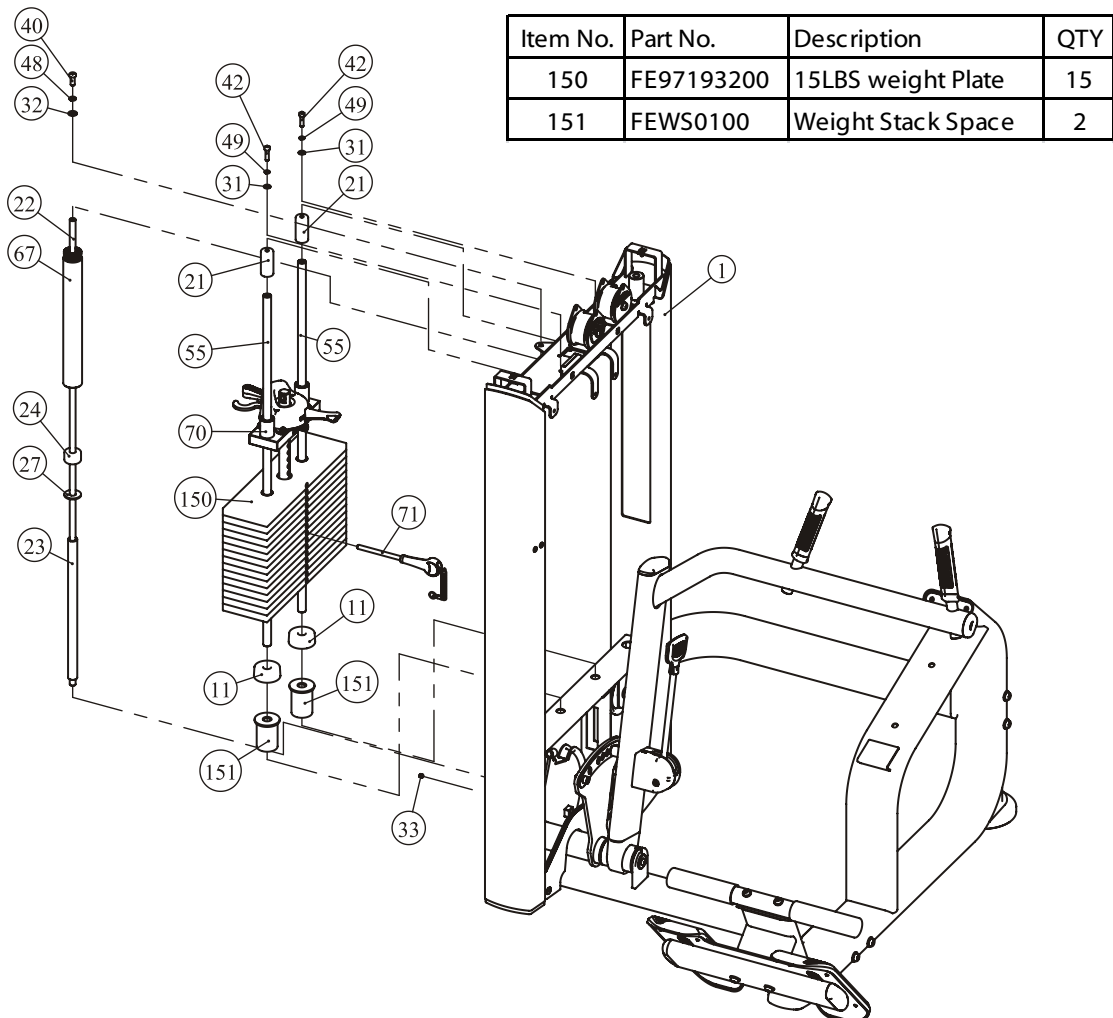

Assembly

STEP 4 Here is the assembly instruction for 15LBSx19PCS Weights !

1. Attach:

two $\Phi 19 \times 974$ Guide Rods (#55)
 nineteen Weight Plate 15LBS (#150)
 to The Weight Stack Frame Assy (#1) using:
 two M8*30 SHCS (#42)
 two $\Phi 30 \times 65$ Rubber Sleeve (#21)

two $\Phi 63.5 \times \Phi 19 \times 25.4$ Plug Bumper (#11)
 one Top plate ASSY (#70)
 two $\Phi 9 \times \Phi 16 \times 1.6$ Flat Washers (#31)
 two $\Phi 8$ Spring Washer (#49)

2. Attach The Selector Pin W/Coil (#71) to The Top plate ASSY (#70).

3. Loosen one M8*8 Screw (#33), and Attach:

one $\Phi 14 \times 1296$ Guide Rod (#22)
 to The Weight Stack Frame Assy (#1) using:
 one $\Phi 22 \times 2 \times 387$ Limiting tube (#23)
 one $\Phi 14 \times \Phi 40 \times 25.4$ Plug Bumper (#24)
 one $\Phi 10$ Spring Washer (#48)

one 5LBS Counter Weight ASSY (#67)
 one $\Phi 15 \times \Phi 40 \times 3$ Flat Washer (#27)
 one M10*25 SHCS (#40)
 one $\Phi 11 \times \Phi 20 \times 2$ Flat Washer (#32)

4. Wrench Tighten M8*8 Screw (#33).

Note: Wrench Tighten Bolts and Nylon Lock Nuts.

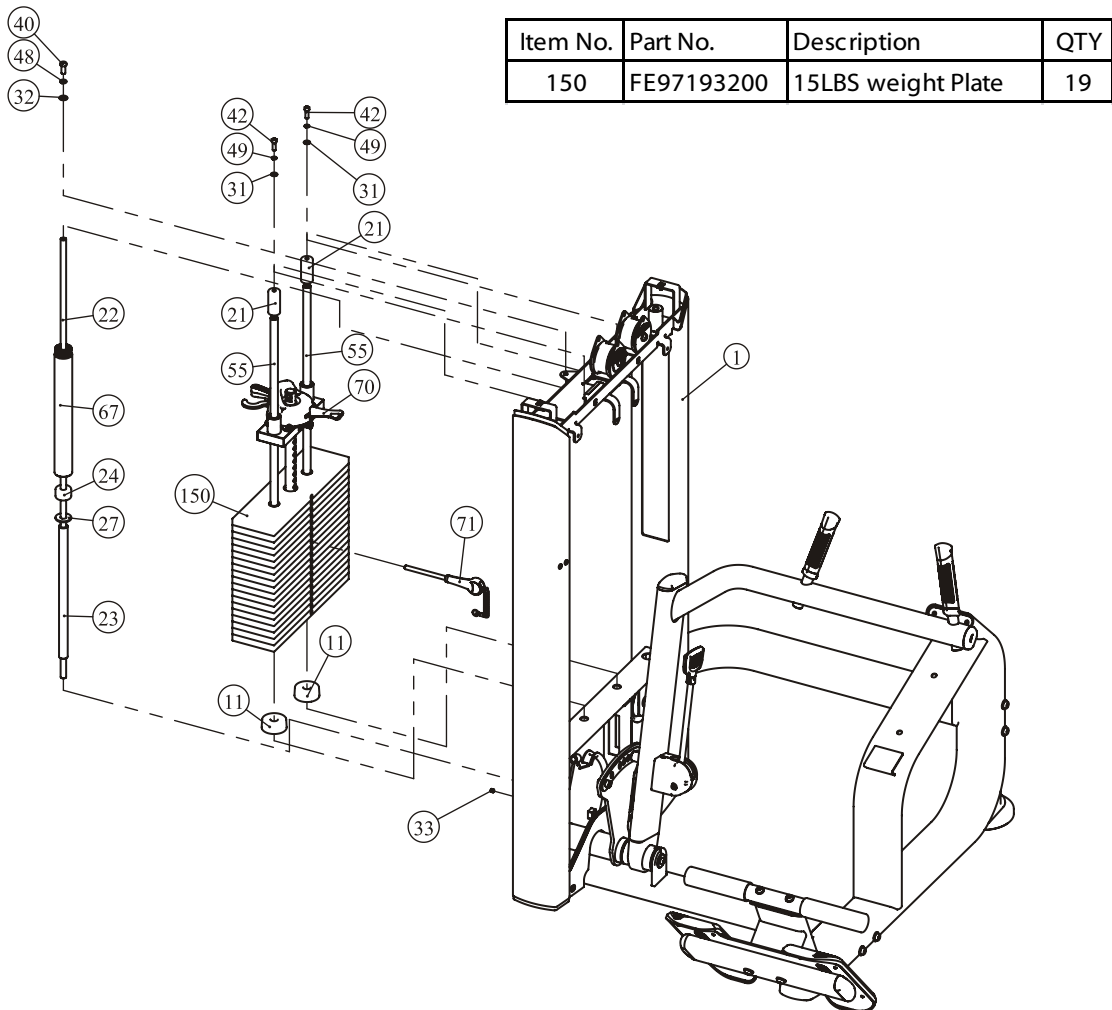

Item No.	Part No.	Description	QTY
150	FE97193200	15LBS weight Plate	19

Assembly

Please assemble according to the actual **Weights** you buy !

10LBS×15PCS

10LBS×19PCS

Grade No.	Part No.	Description	QTY	Grade No.	Part No.	Description	QTY
1	FE971930ASSY	10LBS Top Plate ASSY	1	1	FE971930ASSY	10LBS Top Plate ASSY	1
2	FE97193100	10LBS Weight Plate	15	2	FE97193100	10LBS Weight Plate	19
3	IN-D10132900	Weight Rubber Bumpers	2	3	IN-D10132900	Weight Rubber Bumpers	2
4	FEWS01ASSY	Weight Stack Space	2				

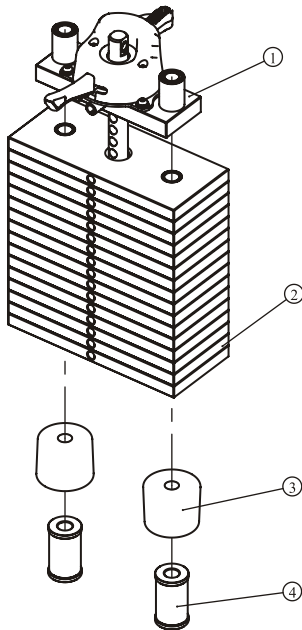

- 20_LBS 9
- 30_LBS 14
- 40_LBS 18
- 50_LBS 23
- 60_LBS 27
- 70_LBS 32
- 80_LBS 36
- 90_LBS 41
- 100_LBS 45
- 110_LBS 50
- 120_LBS 54
- 130_LBS 59
- 140_LBS 64
- 150_LBS 68
- 160_LBS 73
- 170_LBS 77
- 180_LBS 82
- 190_LBS 86
- 200_LBS 91
- 210_LBS 95
- 220_LBS 100
- 230_LBS 104

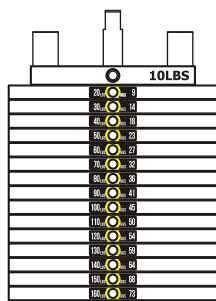
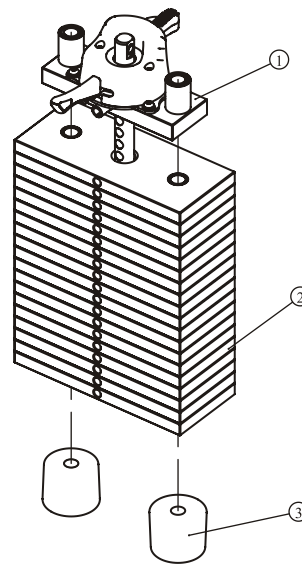

20-160LBS

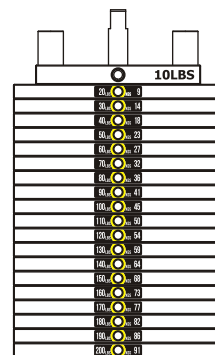

20-200LBS

Weight plate sticker paste schematic diagram

Assembly

Please assemble according to the actual **Weights** you buy !

15LBS×15PCS

15LBS×19PCS

Grade No.	Part No.	Description	QTY	Grade No.	Part No.	Description	QTY
1	FE971930ASSY	10LBS Top Plate ASSY	1	1	FE971930ASSY	10LBS Top Plate ASSY	1
2	FE97193200	15LBS Weight Plate	15	2	FE97193200	15LBS Weight Plate	19
3	IN-D10132900	Weight Rubber Bumpers	2	3	IN-D10132900	Weight Rubber Bumpers	2
4	FEWS01ASSY	Weight Stack Space	2				

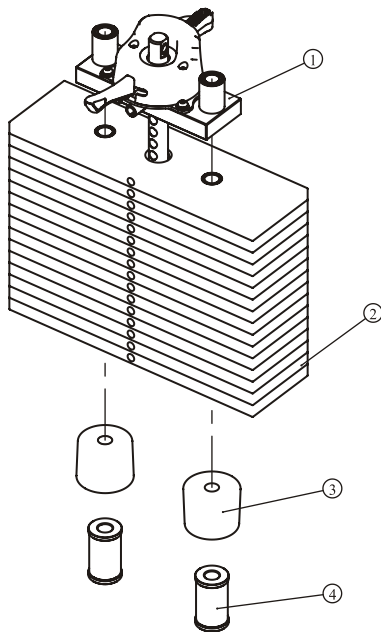

- 25 LBS 11 KGS
- 40 LBS 18 KGS
- 55 LBS 25 KGS
- 70 LBS 32 KGS
- 85 LBS 38 KGS
- 100 LBS 45 KGS
- 115 LBS 52 KGS
- 130 LBS 59 KGS
- 145 LBS 66 KGS
- 160 LBS 72 KGS
- 175 LBS 79 KGS
- 190 LBS 86 KGS
- 205 LBS 93 KGS
- 220 LBS 100 KGS
- 235 LBS 107 KGS
- 250 LBS 113 KGS
- 265 LBS 120 KGS
- 280 LBS 127 KGS
- 295 LBS 134 KGS
- 310 LBS 141 KGS
- 325 LBS 147 KGS

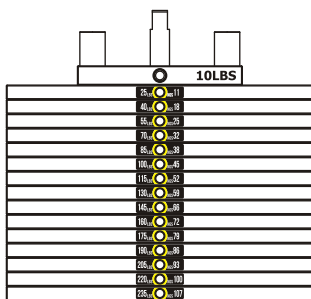
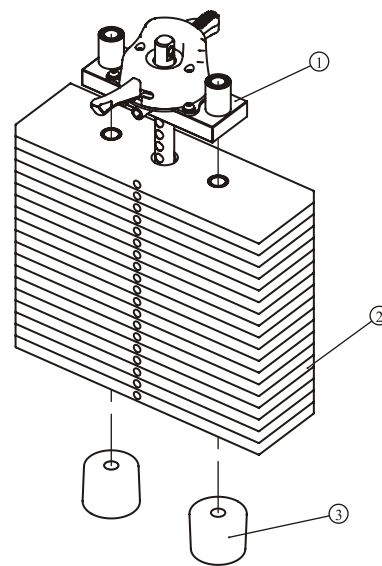

25-235LBS

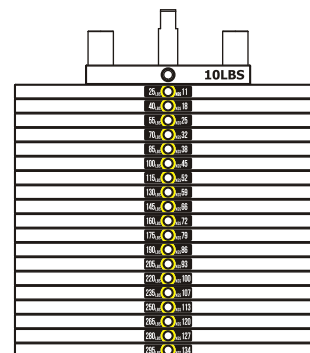

25-295LBS

Weight plate sticker paste schematic diagram

Assembly

Please assemble according to the actual **Weights** you buy !

10LBS×15PCS

10LBS×19PCS

Grade No.	Part No.	Description	QTY	Grade No.	Part No.	Description	QTY
1	FE970230ASSY	40LBS Top Plate ASSY	1	1	FE970230ASSY	40LBS Top Plate ASSY	1
2	FE97193100	10LBS Weight Plate	15	2	FE97193100	10LBS Weight Plate	19
3	IN-D10132900	Weight Rubber Bumpers	2	3	IN-D10132900	Weight Rubber Bumpers	2
4	FEWS01ASSY	Weight Stack Space	2				

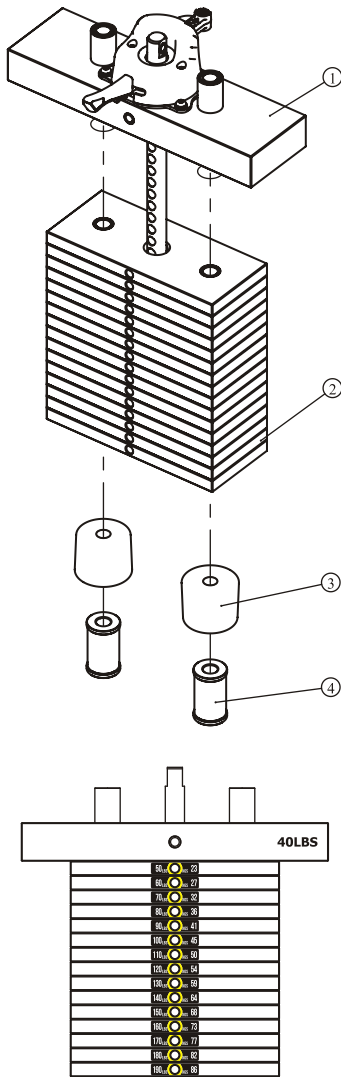

50-190LBS

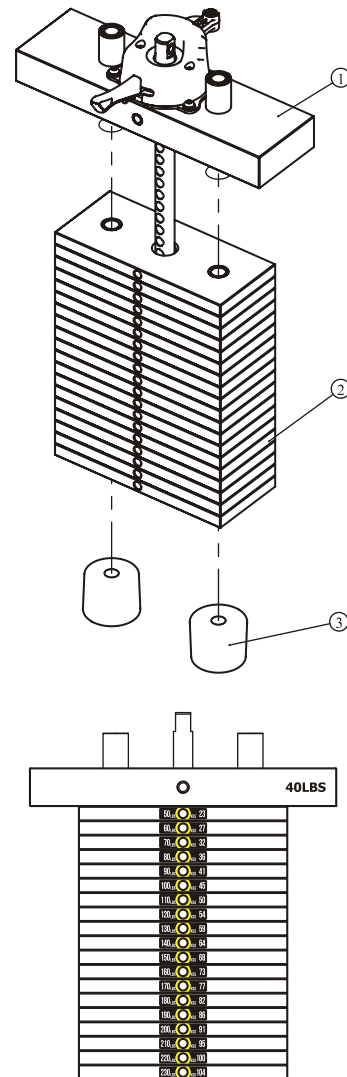

50-230LBS

20 LBS	9
30 LBS	14
40 LBS	18
50 LBS	23
60 LBS	27
70 LBS	32
80 LBS	36
90 LBS	41
100 LBS	45
110 LBS	50
120 LBS	54
130 LBS	59
140 LBS	64
150 LBS	68
160 LBS	73
170 LBS	77
180 LBS	82
190 LBS	86
200 LBS	91
210 LBS	95
220 LBS	100
230 LBS	104

Weight plate sticker paste schematic diagram

Note: 30LBS weight are used the function of balance.

Assembly

Please assemble according to the actual **Weights** you buy !

15LBS×15PCS

15LBS×19PCS

Grade No.	Part No.	Description	QTY	Grade No.	Part No.	Description	QTY
1	FE970230ASSY	40LBS Top Plate ASSY	1	1	FE970230ASSY	40LBS Top Plate ASSY	1
2	FE97193200	15LBS Weight Plate	15	2	FE97193200	15LBS Weight Plate	19
3	IN-D10132900	Weight Rubber Bumpers	2	3	IN-D10132900	Weight Rubber Bumpers	2
4	FEWS01ASSY	Weight Stack Space	2				

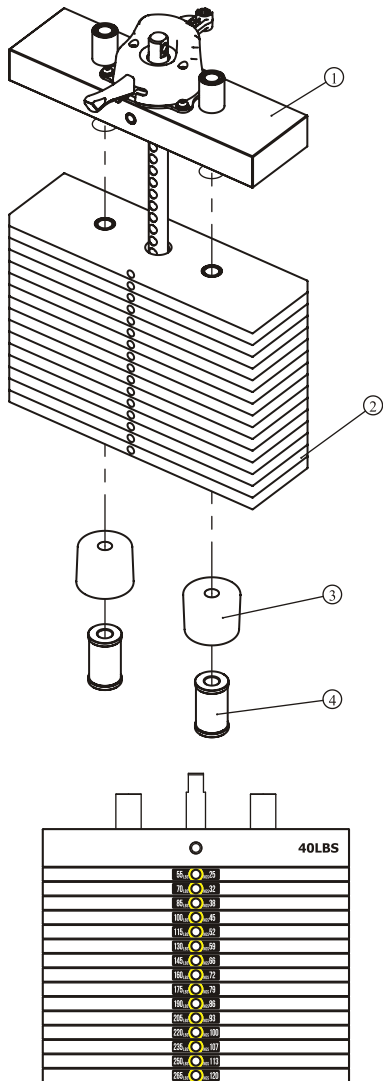

55-265LBS

- 25 LBS 11 KGS
- 40 LBS 18 KGS
- 55 LBS 25 KGS
- 70 LBS 32 KGS
- 85 LBS 38 KGS
- 100 LBS 45 KGS
- 115 LBS 52 KGS
- 130 LBS 59 KGS
- 145 LBS 66 KGS
- 160 LBS 72 KGS
- 175 LBS 79 KGS
- 190 LBS 86 KGS
- 205 LBS 93 KGS
- 220 LBS 100 KGS
- 235 LBS 107 KGS
- 250 LBS 113 KGS
- 265 LBS 120 KGS
- 280 LBS 127 KGS
- 295 LBS 134 KGS
- 310 LBS 141 KGS
- 325 LBS 147 KGS

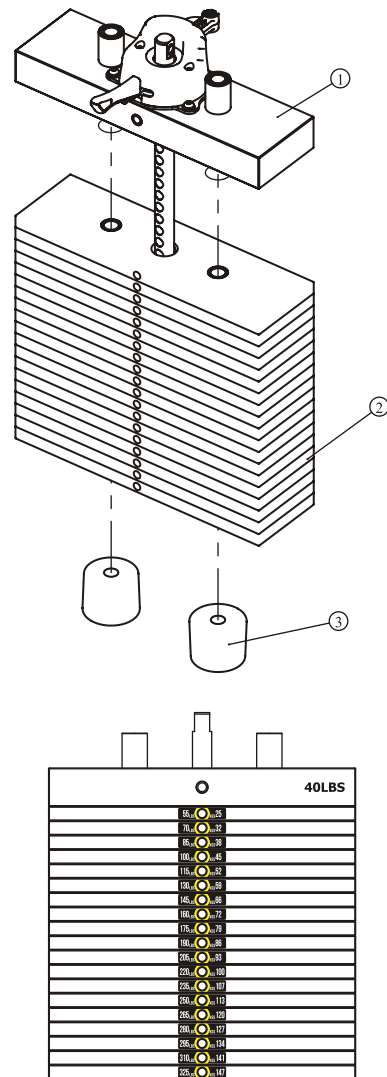

55-325LBS

Weight plate sticker paste schematic diagram

Note: 30LBS weight are used the function of balance.

Assembly

STEP 5

1. Attach one end of The Belt ASSY (#54) to The Weight Stack Frame Assy (#1) using:
one $\Phi 13 \times \Phi 24 \times 2.5$ Flat Washer (#30) one M12 Nylon Lock Nut (#52)
2. Attach the other end of The Belt ASSY (#54) through the Bracket of Belt Pulley (#13), and assemble the $\Phi 76$ Narrow Belt Pulley (#25) to the Bracket of Belt Pulley (#13) using:
one M10*65 SHCS (#38) two $\Phi 11 \times \Phi 20 \times 2$ Flat Washers (#32)
one M10 Nylon Lock Nut (#53)
And through two Belt Pulleys on the Weight Stack Frame Assy (#1).
3. Attach the other end of The Belt ASSY (#54) to the Top plate ASSY (#70) using:
one M10*45 SHCS (#39) two $\Phi 11 \times \Phi 20 \times 2$ Flat Washers (#32)
one M10 Nylon Lock Nut (#53)
4. Attach two $\Phi 17 \times 49$ Belt Rubber Sleeves (#28) to the Weight Stack Frame Assy (#1) using:
two $\Phi 13 \times \Phi 8 \times 65.5$ Spacer Pins (#73) two $\Phi 6$ Shaft Ring Opening (#51)
5. Attach the Cable (#56) to The CAM ASSY (#4) and The Bracket of Belt Pulley (#13) using:
one M10*45 SHCS (#39) two $\Phi 11 \times \Phi 20 \times 2$ Flat Washers (#32)
one M10 Nylon Lock Nut (#53)

Note: Wrench Tighten Bolts and Nylon Lock Nuts.

Step 6

1. Attach the Back Lower Cover (#60) to the Weight Stack Frame Assy (#1) using:
three M6*20 BHCS (#45) three $\Phi 6.6 \times \Phi 12 \times 1.6$ Flat Washers (#29)
2. Attach two Front Shroud (#58) to the Front Lower Cover (#57) on the Weight Stack Frame Assy (#1).
3. Assemble the Console PCB, and attach the Training Placard Cover ASSY (#62) to the Weight Stack Frame Assy (#1) using:
four M6*15 BHCS (#43) four $\Phi 6.6 \times \Phi 12 \times 1.6$ Flat Washers (#29)
4. Attach the Back Shroud (#61) to the Back Lower Cover (#60) and the Weight Stack Frame Assy (#1) using:
two $\Phi 6.6 \times \Phi 12 \times 1.6$ Flat Washers (#29) two M6*20 BHCS (#45)
5. Attach the Top Cover (#59) to the Weight Stack Frame Assy (#1) using:
two M6*20 BHCS (#45) two $\Phi 6.6 \times \Phi 12 \times 1.6$ Flat Washers (#29)

Note: Wrench Tighten Bolts.

Assembly

STEP 5

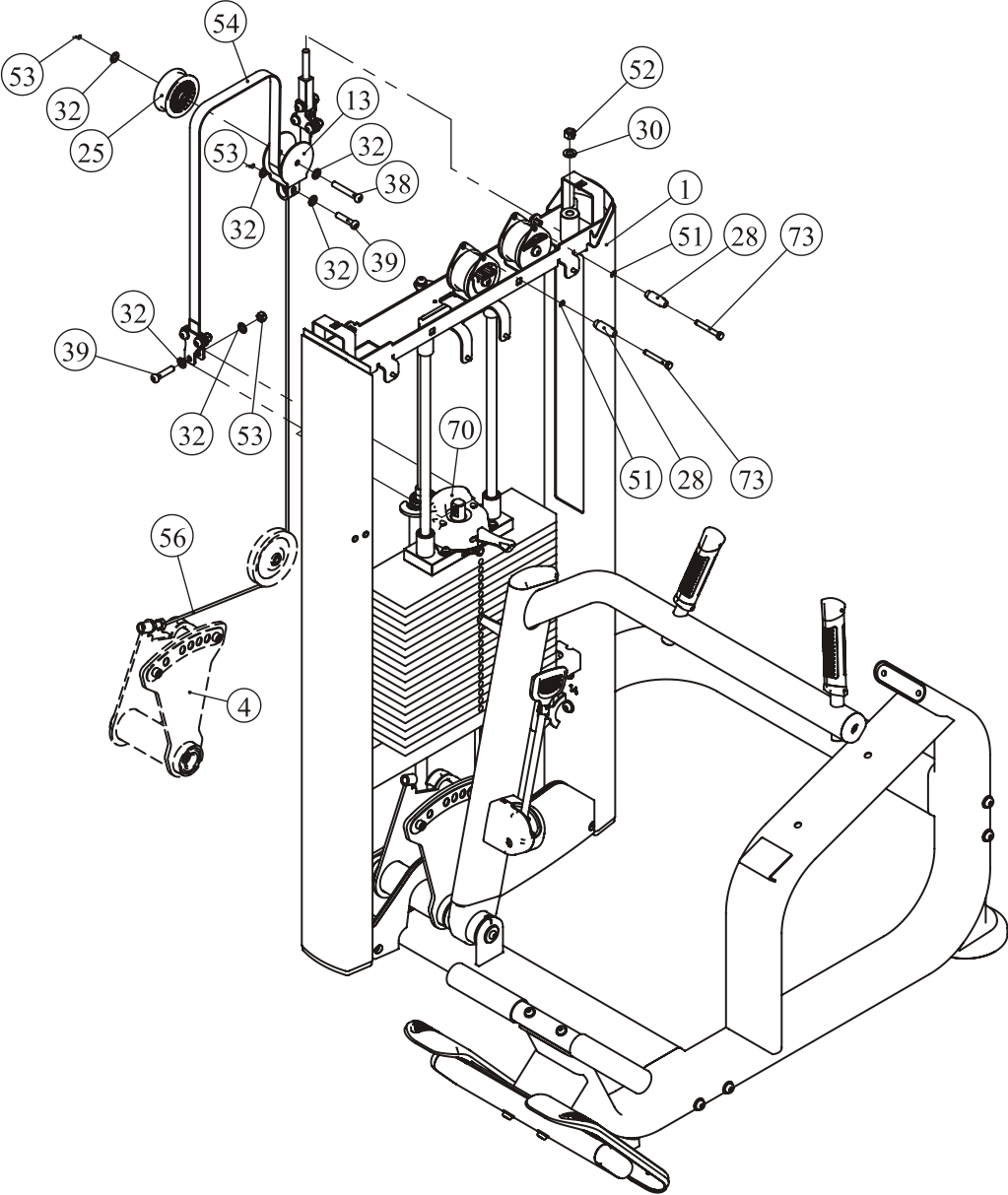

Assembly

STEP 6

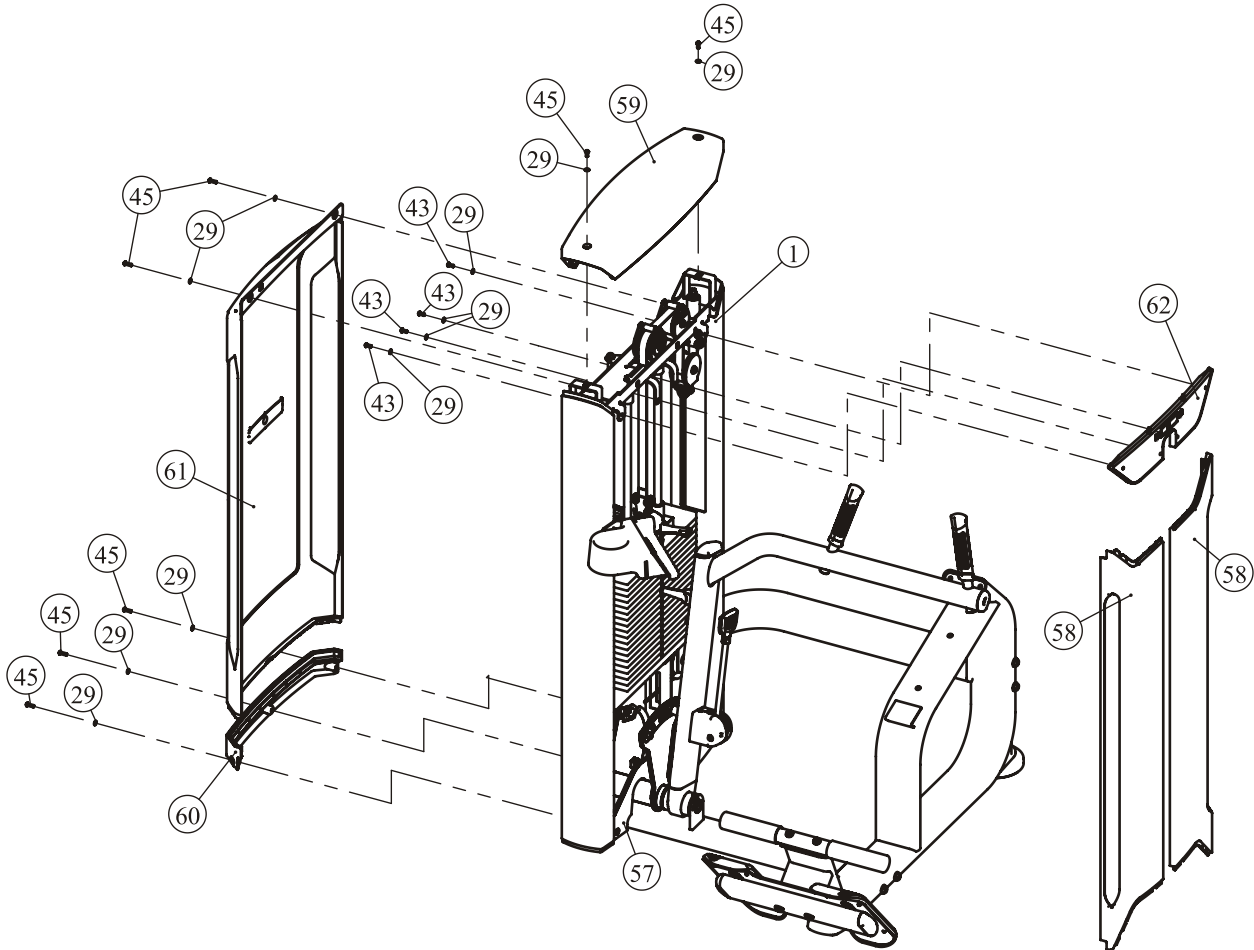
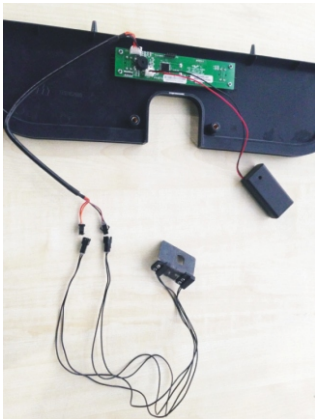
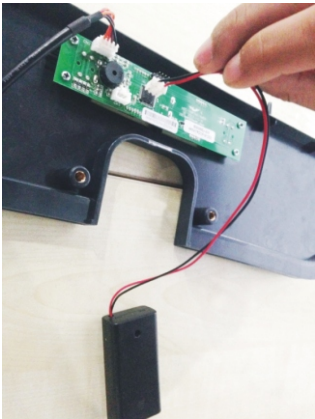

Assembly

STEP 7

1. Attach the Plastic End Cap (#72) to the Cup Holder (#16).
Attach the Plastic End Cap (#72) and the Cup Holder (#16) to the Bracket of Cup Holder (#17) using:
two M6*15 BHCS (#43)
Attach the Assemble good parts (#17/#16/#72) to the Weight Stack Frame Assy (#1) using:
two $\Phi 6.6 \times \Phi 12 \times 1.6$ Flat Washers (#29) two M6*20 BHCS (#45)
two $\Phi 6$ Spring Washer (#50)
2. Attach the Seat Pad (#18) to the Main Frame ASSY (#2) using:
two M10*65 SHCS (#38) two $\Phi 11 \times \Phi 20 \times 2$ Flat Washers (#32)
3. Attach the Waist Pad Cover (#69) to the Main Frame ASSY (#2).
Attach the Waist Pad Plate (#26) to the Main Frame ASSY (#2) using:
two M12*30 Flat Head Cap Screw (#44)
4. Attach the Waist Pad (#20) to the Main Frame ASSY (#2) using:
two M10*25 Socket Head Cap Screw (#40)

Note: Wrench Tighten Bolts and Nylon Lock Nuts.

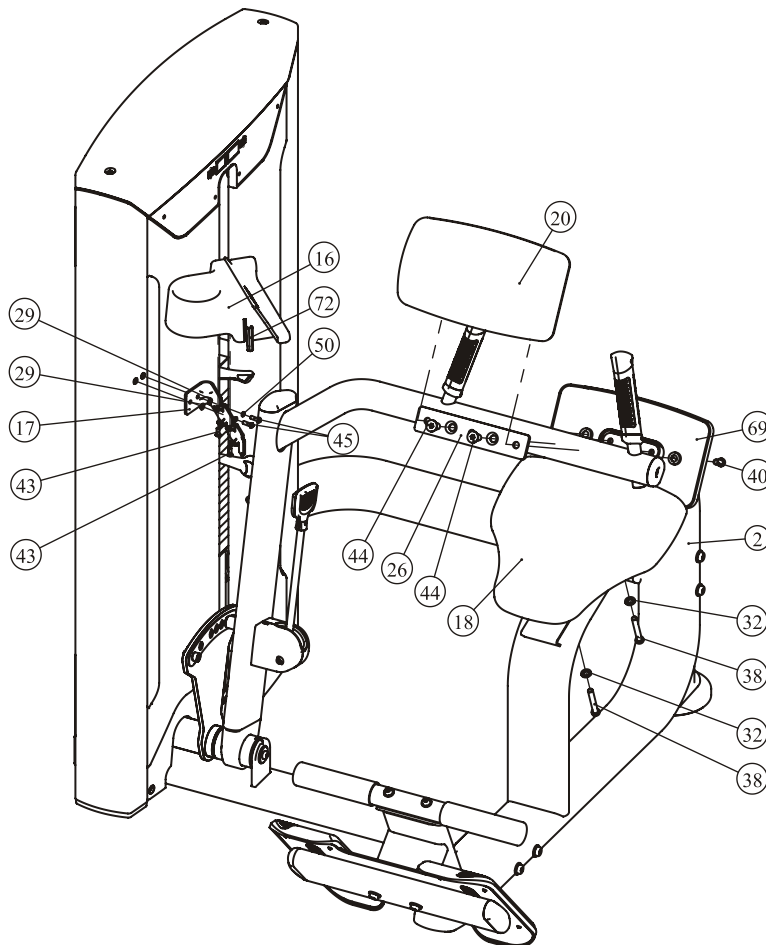

Adjust Instructions

The use of Selector Pin W/Coil

1. Select an appropriate weight and put the Selector Pin W/Coil into the hole on it.
2. Make sure the Selector Pin W/Coil gets into the hole completely.

The 5LBS Counter Weight adjustment

1. Toggle the Shifting Fork to the desired position.
2. Make sure the Shifting Fork get into the Fillister completely.

The Turn Arm Frame Assy adjustment

1. Pull the Adjustment Handle, and adjust the Turn Arm Frame Assy to the desired position.
2. Make sure the pin get into the hole completely.

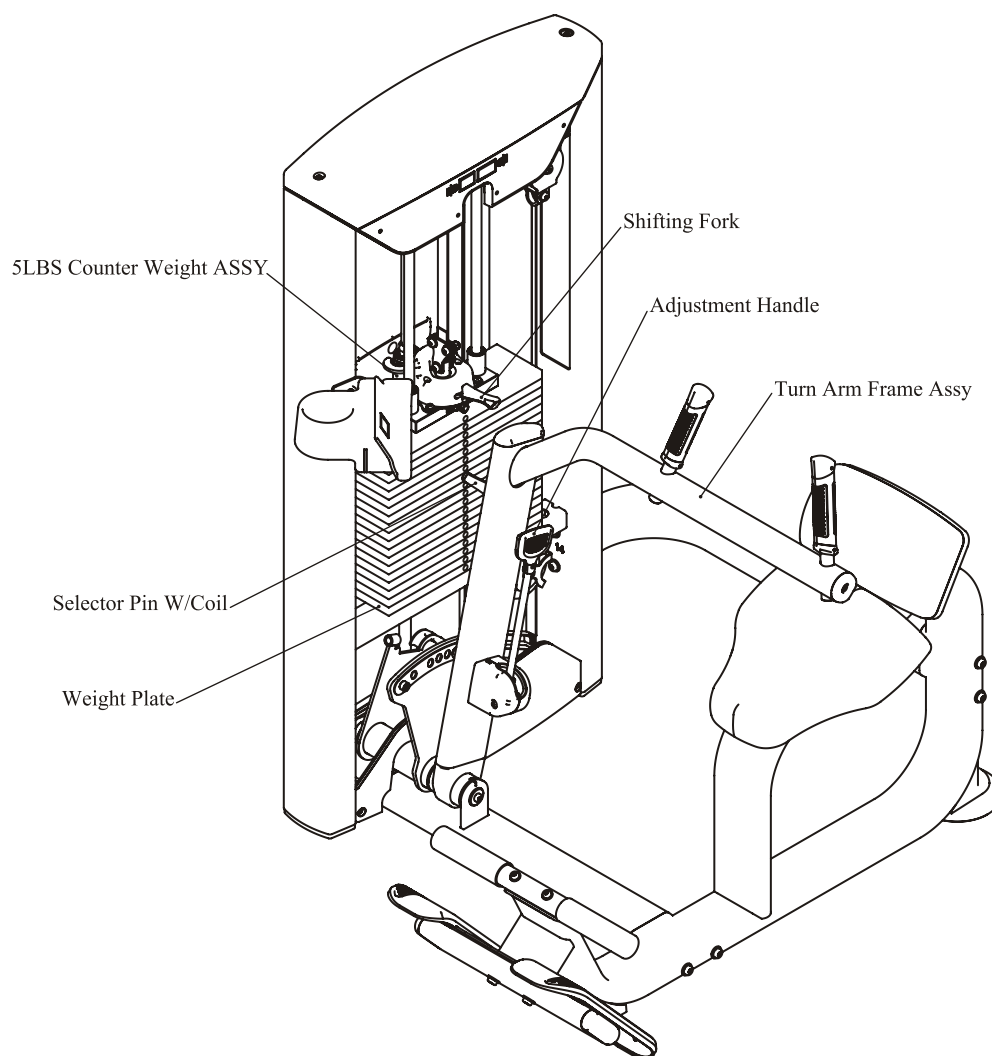

Exercise Instructions

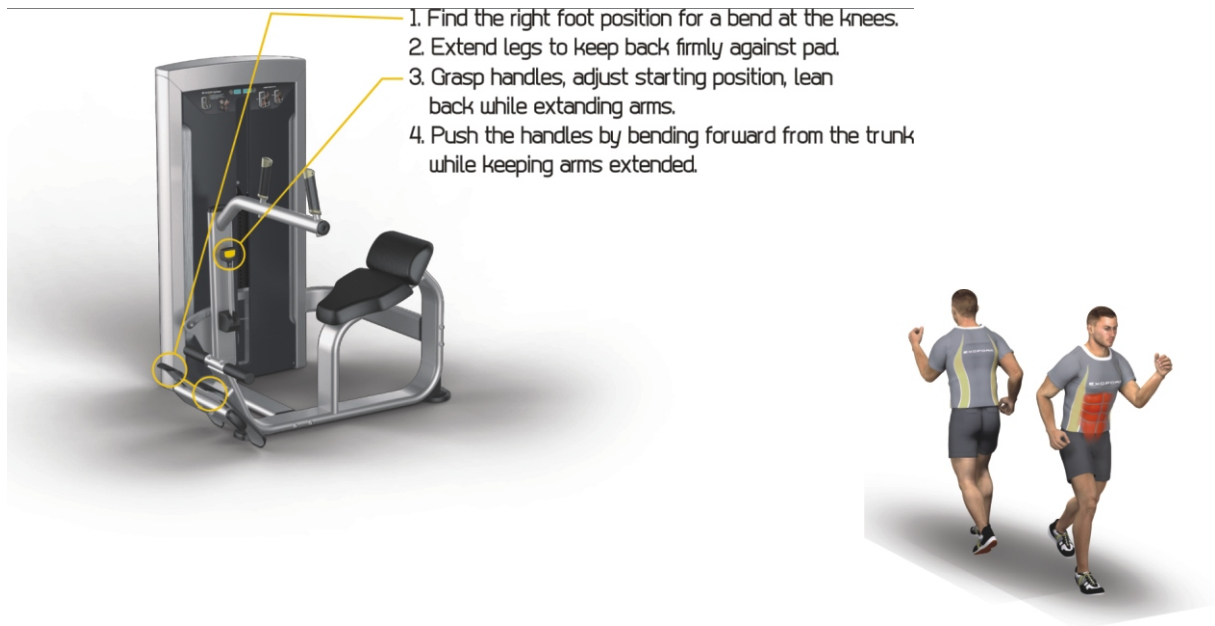
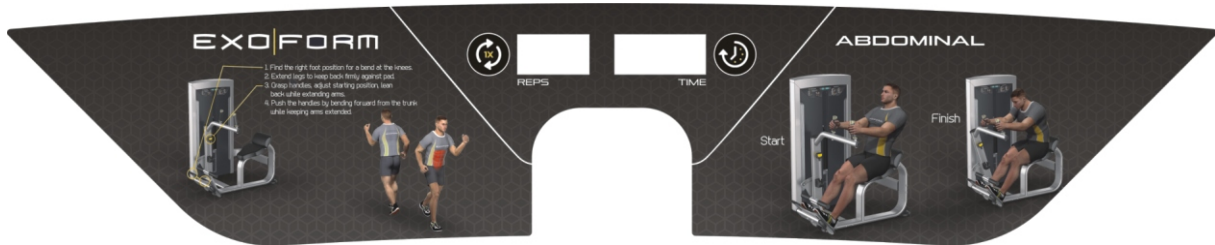

Console Panel Function



1. CONSOLE PANEL FUNCTION

1.1 TIME WINDOW

Indicates elapsed time after pressing start in minutes and seconds (0-99minutes, 0-59seconds).

1.2 REPS WINDOW

Indicates times of workout cycle (0-999).

2. BUTTONS

2.1 REPS RESET: Reset value of REPS window.

2.2 TIME RESET: Reset value of TIME window

3. SAVE POWER MODE

3.1 Switched on automatically when there is signal input.

3.2 The screen turn off of self after 3 minutes in stop station.

Battery Replacement

Battery replacement

For this computer you need 2 pcs. 1.5V AA batteries. If the display quality gets poor, you should replace the battery. Therefore please open the battery case cover on the back side of your computer and replace the old battery by a fitting new one. Close the case cover properly.



You must check the batteries regularly to prevent leakage from damaging console.

Battery-Disposal

Batteries should not be considered as regular garbage. As consumer you are obliged to return finished batteries. The finished batteries can be returned to a collection base at your residential area or at places, where batteries can be bought.



WE RECOMMEND THE USE OF ALCALI-MANGAN BATTERIES.

You will find these symbols on batteries, which contain harmful substances:

Pb = Battery contains lead

Cd = Battery contains cadmium

Hg = Battery contains mercury



Pb



Cd



Hg

Maintenance Schedule

ROUTINE	COMMERCIAL MAINTENANCE	HOME MAINTENANCE	LATEST DATE ENTRY						
Inspect; Links, Pull Pins, Snap Locks, Swivels, Weight Stack Pins	DAILY	WEEKLY							
Clean; Upholstery	DAILY	WEEKLY							
Inspect; Cables or Belts and their tension	DAILY	WEEKLY							
Inspect; Accessory Bars, and Handles	WEEKLY	3 MONTHS							
Inspect; All Decals	WEEKLY	3 MONTHS							
Inspect; All Nuts and Bolts, Tighten if needed	WEEKLY	3 MONTHS							
Inspect; Anti-Skid Surface	WEEKLY	3 MONTHS							
Clean & Lubricate; Guide Rods with a Teflon (PTFE) based lubricant (Superlube)	MONTHLY	3 MONTHS							
Lubricate; Seat Sleeves, Turcite Bushings, Linear Bearing	MONTHLY	3 MONTHS							
Clean and Wax; All Glossy Finishes	6 MONTHS	YEARLY							
Repack with Grease; Linear Bearings	6 MONTHS	YEARLY							
Replace; Cables, Belts and Connecting Parts	YEARLY	3 YEARS							

Your equipment comes with a commercial maintenance decal. For personal, in home use, please follow the home maintenance schedule listed above.

General Maintenance Information

Links, Pull-Pins, Snap Hooks, Swivels, Weight Stack Pins:

- * Check all pieces for signs of visible wear or damage.
- * Check springs in snap hooks and pull-pins for proper tension and alignment.
- * If the spring sticks or has lost its rigidity, replace it immediately.

Upholstery:

- * To ensure prolonged upholstery life and proper hygiene, all upholstered pads should be wiped down with a damp cloth after every workout.
- * Periodically take the time to use a mild soap or an approved vinyl upholstery cleaner to deter the onset of cracking or drying. Avoid using any abrasive cleaners or cleaners not intended for use on vinyl.
- * Replace ripped or worn upholstery immediately.
- * Keep sharp or pointed objects clear of all upholstery.

Decals:

- * Inspect and familiarize yourself with any safety warnings or other user information posted on each decal.

Nuts and Bolts:

- * Inspect all nuts and bolts for any loosening and tighten if needed.
- * Go through a re-tightening sequence periodically to ensure that all hardware is tensioned proper.

Anti-Skid Surfaces:

- * These surfaces are designed to supply secure footing and need to be replaced if they appear worn or become slippery.

Belts and Cables:

- * We use only high quality belt, and mil-spec cables.
- * Visually inspect the belts and cables for fraying, cracking, peeling or discoloration.
- * While the machine is not in use, carefully run your fingers along the belt or cable to feel for thinning or bulging areas.
- * Replace belts and cables immediately at the first signs of damage or wear. Do not use equipment until belts or cables have been replaced.

Belt and Cable Tension:

- * Referring to the Owners Manual, when belts or cables are used check all bolts attachments to be sure they are properly attached.
- * Check slack in cables and re-adjust cable tension if needed.

Seat Sleeves, Guide Rods:

- * Wipe down adjusting tubes with a dust free rag before applying lubricant.
- * Lubricate seat sleeves and Guide Rods with a Silicon or Teflon based lubricant spray.

Linear Bearings:

- * Referring to the Owners Manual carefully disassemble the bearing from its housing and place a finger full of light grease (lithium, super lube, etc.) into the inside of the bearing. Using your finger, press the grease into the ball-bearings and their tracks. Repeat until the ball-bearing tracks are full of grease. Insert the shaft back into the bearing and wipe off excess grease.

PLEASE KEEP THIS FOR YOUR RECORDS

Weight Training Tips

Use this manual to guide you through the basic exercises you can perform on your equipment. To gain maximum results and avoid possible injury, consult a fitness professional to develop your complete exercise program.

Always consult your physician before starting any exercise program.

To be successful in your exercise program, it is important to develop an understanding of the basic principles of strength training. Now that you have your equipment, it is only natural that you want to get started immediately. First, determine a set of realistic goals and objectives for yourself. By deciding on an exercise plan that is right for you prior to starting, you will contribute significantly to your success.

Warm up properly before engaging in weight resistance training. Stretching, yoga, jogging, calisthenics or other cardiovascular exercise can help prepare your body for the heavier workload of lifting weights.

Learn how to perform the exercise correctly before using heavy weight. Correct form is important to avoid injury and to ensure that you work the proper muscle groups.

Know your limitations. If you are new to weight training or are embarking on an exercise regimen after a long layoff, start slowly and build foundational strength over a longer period of time.

Pay attention to your breathing. Exhale when you exert is a general rule of thumb. Never hold your breath.

